

DPC-D245

2-wire door station



User manual

Introduction

The door station is designed with high resolution color CCD camera, it provides wide angle of 105° for 2-wire intercom system. The high white LED for night view makes the door station working efficiently at night.

The front panel is made of plexiglass or stainless steel with rainy cover for better protection against water. One or two touch sensor call button can be selected. The large name label with white backlight is covered by a fully secured and flameproof glass plate.

Parts and Function

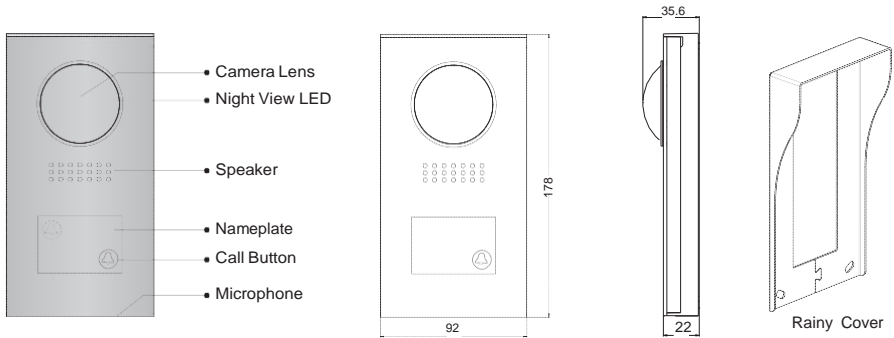

Note:the door station support two call buttons to control two users.

Terminal Description

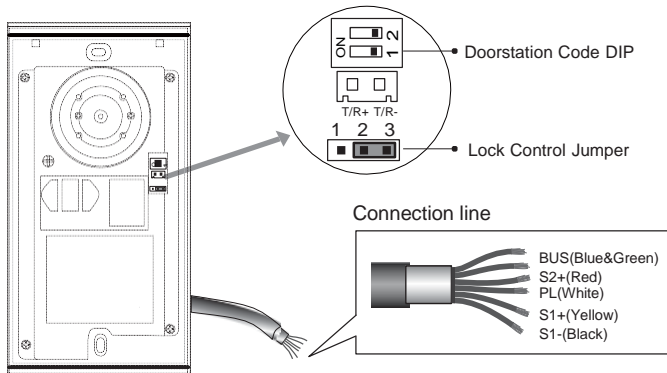

Lock Control Jumper: To select the lock type.

Door Station Code DIP: Total 4 door stations can be supported.

T/R+,T/R-: USB-RS485 communication terminal.

Main Connect Port: To connect the bus line and the electronic locks.

BUS(Blue&Green): Connect to the bus line, non-polarity.

PL(White): External lock power input, connect to the power positive(power +).

S1+(Yellow): The first lock power(+) output.

S2+(Red): The second lock power(+) output.

S-(Black): Lock power(-) output.

Door Station Mounting

Mounting with rainy cover

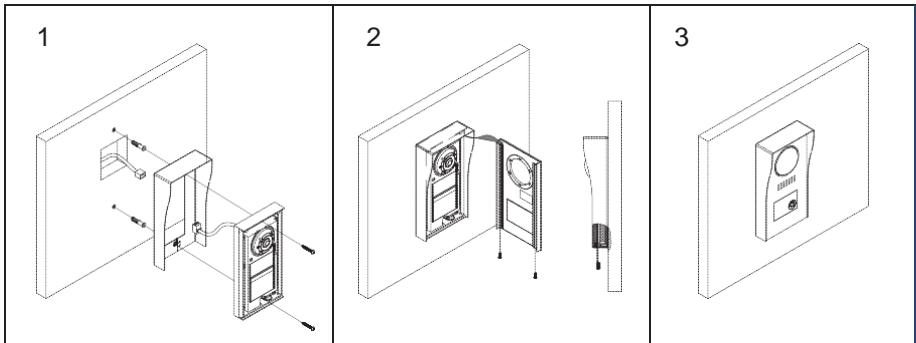

Mounting without rainy cover

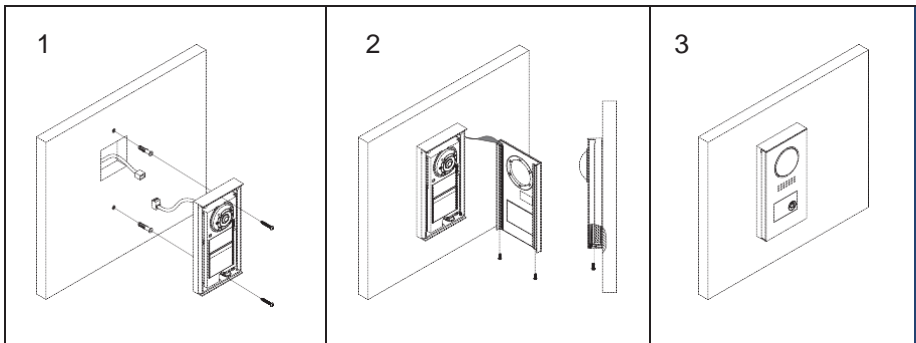

The location of the unit should keep away from snow,rain,and intensity light.

Installation Steps:

Installation height for door station usually is 145~160cm.

1. Use screws to fix the back panel and rainy cover(if mounting with rainy cover) to the wall after connect the cable correctly.
2. Attach the front panel to the back panel, then use the screw to fix it.

Adjusting Camera Angle

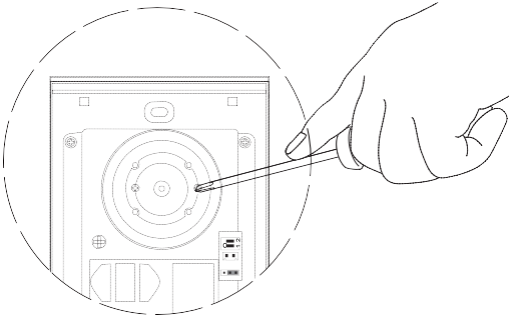

Use a screwdriver to loosen the screw and then adjust the angle of the camera ,then fix the screw.

System Wiring and Connections

Basic one-to-one Connection

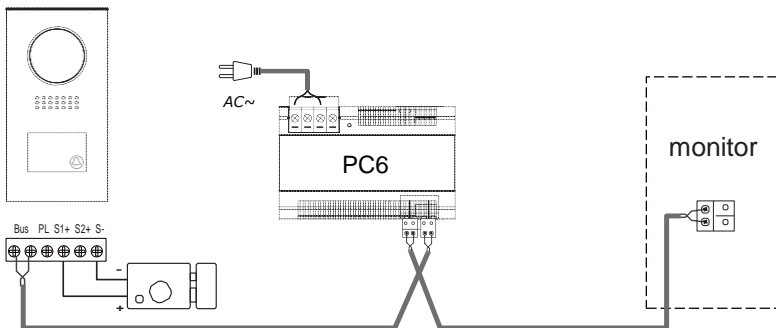

Multi Door Stations Connection

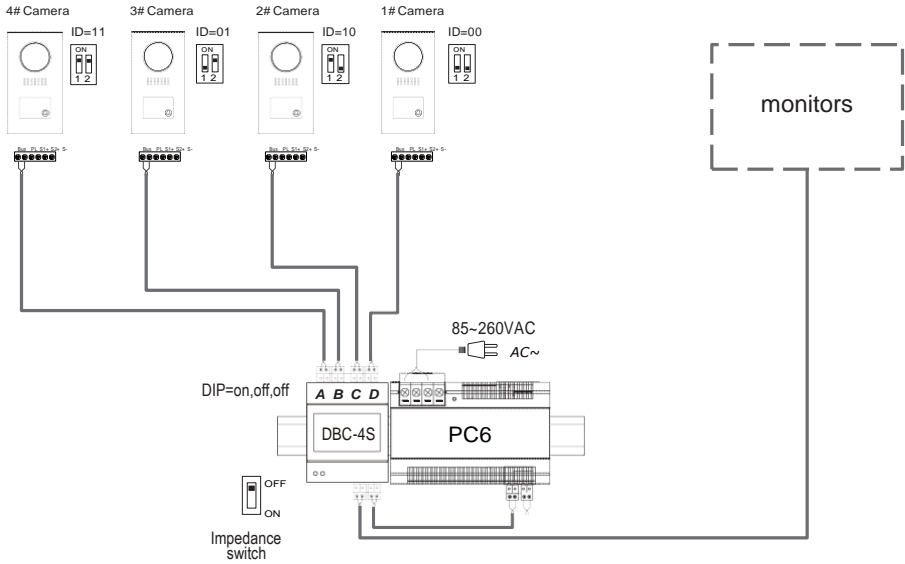

Multi Monitors Connection

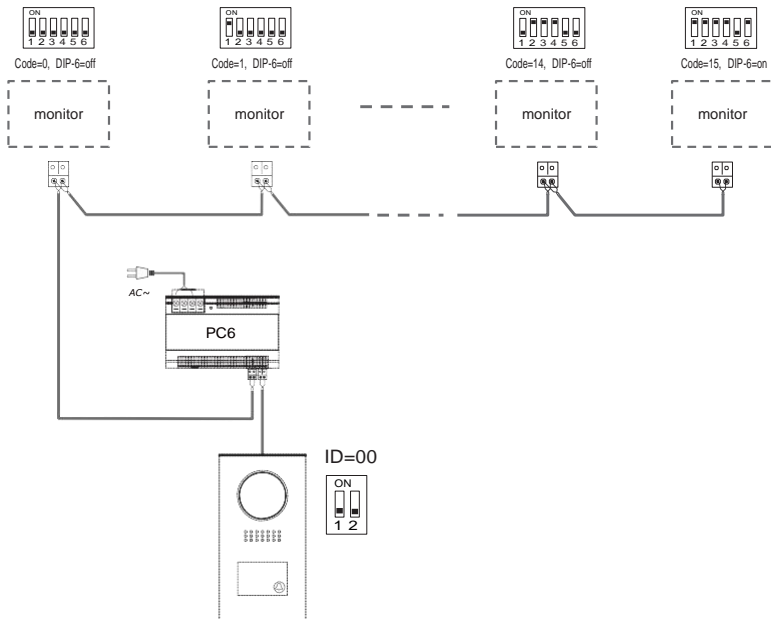

With DBC-4 Wiring Mode

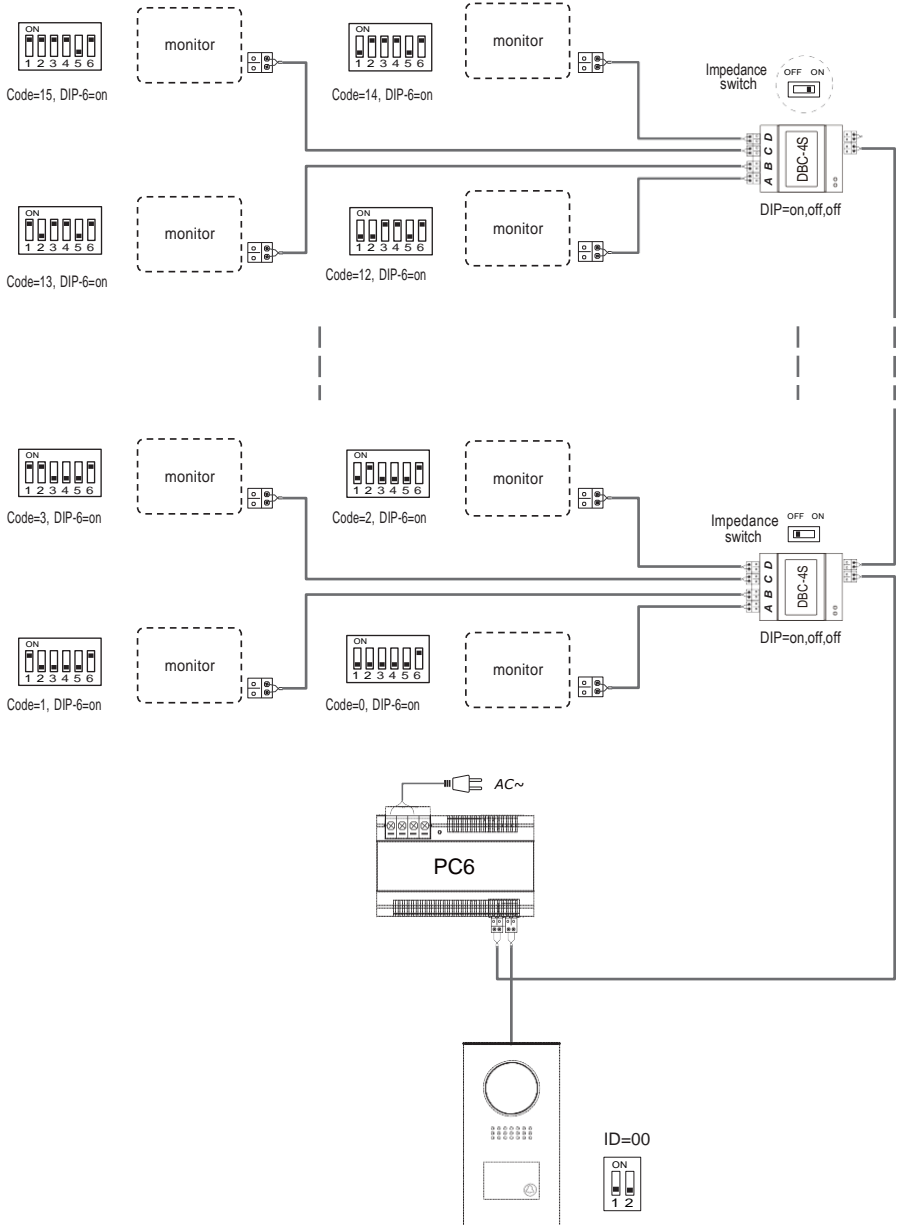

Electric Lock Connection

Door Lock Controlled with Internal Power

Note:

1. Electronic lock of Power-on-to-unlock type should be used.
2. The door lock is limited to 12V, and holding current must be less than 250mA.
3. The door lock control is not timed from Exit Button(EB).
4. The **Unlock Mode** Parameter of Monitor must be set to 0 (by default).

connect one lock

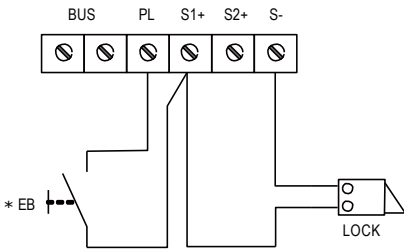
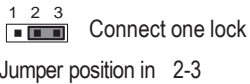

connect two locks

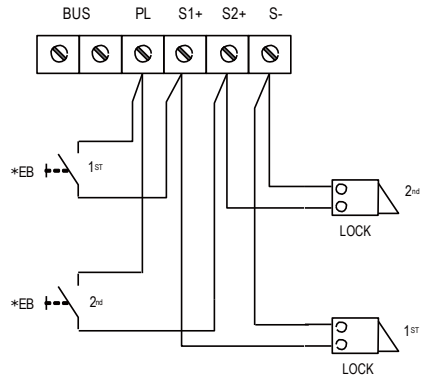
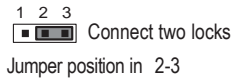

Door Lock Controlled with Dry Contact

Note:

1. The external power supply must be used according to the lock.
2. Setup the **Unlock Mode** of Monitor for different lock types.
 - Power-on-to-unlock type:Unlock Mode=0 (by default)
 - Power-off-to-unlock type:Unlock Mode=1

connect one lock

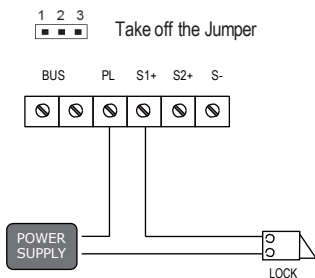

connect two locks

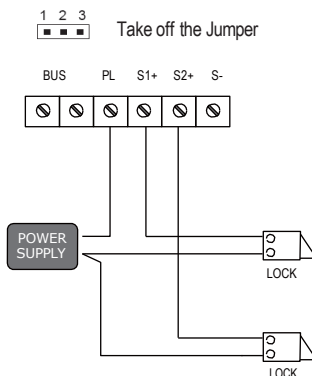

5.2.3 Unlock parameter setting(set on monitor)

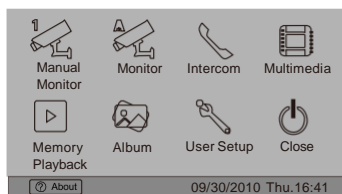

1. Touch **About** item on main menu page.

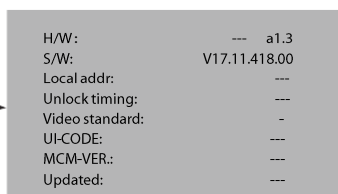

2. Touch the screen anywhere and hold for 2s.

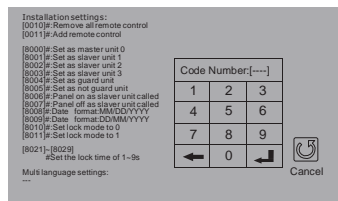

4. A digital keypad and setting instructions will be shown.



3. Touch Installer setup item

Note:

1. must connect correctly before setting.
2. the parameter will be saved in door station automatically, so you need only set on one monitor.
3. the above diagram is fit for icon menu series monitors only, to text menu series monitors, please refer to the corresponding user manual.



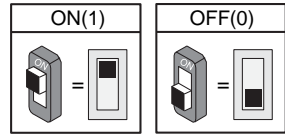

DIP Switches Setting

The DIP switch is designed to set the code for door station and monitor, there are two states for each DIP switch, please refer to the sketch map.



Door station DIP setting



Total 2 bits can be configured, bit-1 and bit-2 are used to assign ID code for door station. The switches can be modified either before or after installation.

Bit state	Descriptions
	Default setting, ID = 0(00), set to the first Door Station.
	ID = 1(10), set to the second Door Station.
	ID = 2(01), set to the third Door Station.
	ID = 3(11), set to the fourth Door Station.

Indoor monitor DIP setting

































There are 6 bits in total. The DIP switches are used to configure the user code for Monitors.

Bit-6 is a video impedance match switch, which have to be set to ON if match the impedance, otherwise set to OFF.

Bit state	Setting	Bit state	Setting
	Not match		Match the video impedance

Bit-1~Bit-5 are used to set user code. If the door station with one call button, the user code should be set to 0~15. If the door station with two call buttons, the user code should be set to 0~31.

Please refer to the following settings:

Bit state	User code	Bit state	User code	Bit state	User code
	code=0		code=11		code=22
	code=1		code=12		code=23
	code=2		code=13		code=24
	code=3		code=14		code=25
	code=4		code=15		code=26
	code=5		code=16		code=27
	code=6		code=17		code=28
	code=7		code=18		code=29
	code=8		code=19		code=30
	code=9		code=20		code=31
	code=10		code=21		

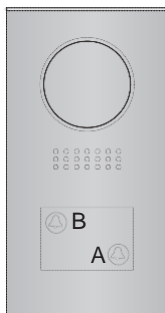
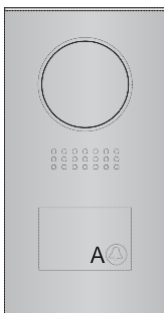

Note: Monitors response button A must set the user code from 0 to 15. and button B set the user code from 16 to 31.

Cables Requirements

The maximum distance of the wiring is limited in the DT system. Using different cables may also affect the maximum distance which the system can reach.

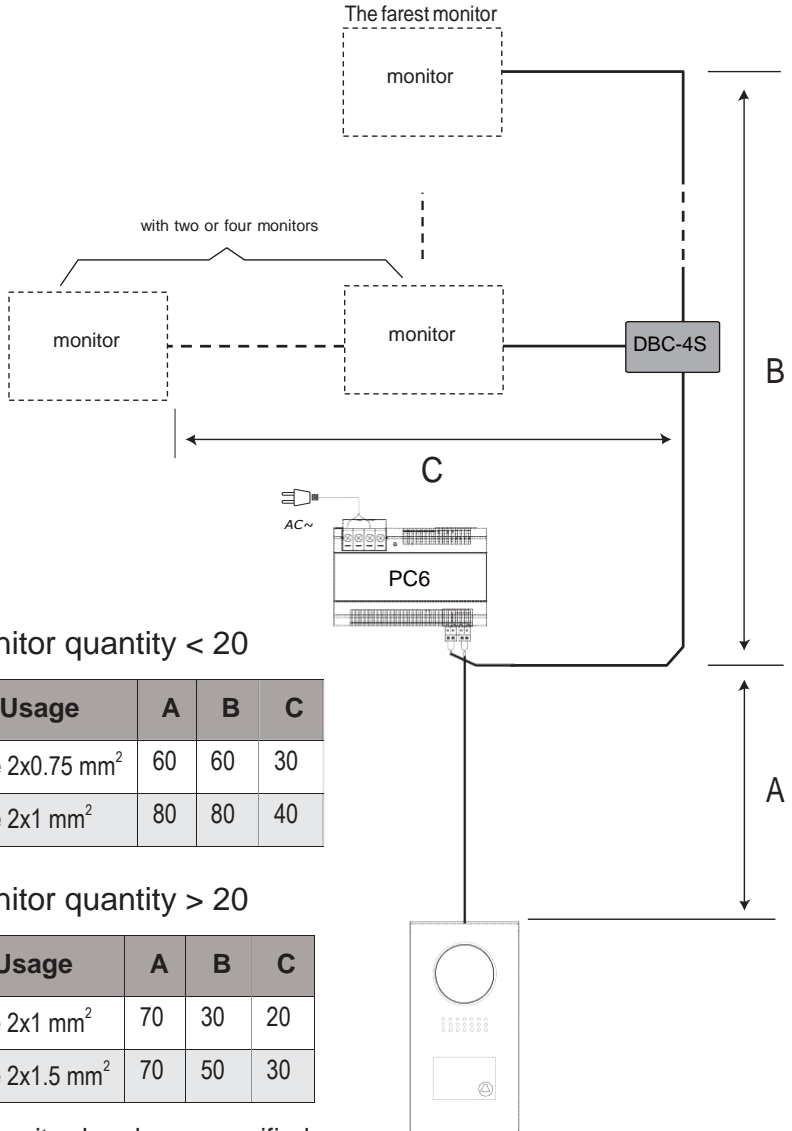

When Monitor quantity < 20

Cable Usage	A	B	C
Twisted cable 2x0.75 mm ²	60	60	30
Twisted cable 2x1 mm ²	80	80	40

When Monitor quantity > 20

Cable Usage	A	B	C
Twisted cable 2x1 mm ²	70	30	20
Twisted cable 2x1.5 mm ²	70	50	30

Note: If the monitor has been specified the distance, refer to the parameter.

Specification

Power Supply : DC 24V (supplied by PC6);

Power Consumption: Standby 60mA; Working status 200mA;

Camera: 1/4 ACS 4T image sensor with DSP processor

Lock Power supply: 12Vdc, 300mA(Internal Power);

Working temperature: -10°C ~ +45°C

Dimension: 188(H)×110(W)×34(D)mm

Precautions

- Please clean the unit with soft cotton cloth, don't use the organic impregnant or chemical clean agent. If necessary, please use a little pure water or dilute soap water to clean the dust.
- The unit is weather resistant. However do not spray high pressure water on access control keypad directly. Excessive moisture may cause problems with the unit.
- You must use the right adaptor which is supplied by the manufacturer or approved by the manufacturer.
- Pay attention to the high voltage inside the products, please refer service only to a trained and qualified professional.