



# **Internet Camera**

## **ICA-100C**

### **User's Manual**

*Version 2.0*

## Copyright

Copyright (C) 2005 PLANET Technology Corp. All rights reserved. The products and programs described in this User's Manual are licensed products of PLANET Technology, This User's Manual contains proprietary information protected by copyright, and this User's Manual and all accompanying hardware, software, and documentation are copyrighted.

No part of this User's Manual may be copied, photocopied, reproduced, translated, or reduced to any electronic medium or machine-readable form by any means by electronic or mechanical. Including photocopying, recording, or information storage and retrieval systems, for any purpose other than the purchaser's personal use, and without the prior express written permission of PLANET Technology.

## Declaration of Conformity

This device complies with part 15 of the FCC Rules. Operation is subject to the following two conditions:

- (1) this device may not cause harmful interference, and
- (2) this device must accept any interference received, including interference that may cause undesired operation.

## Disclaimer

PLANET Technology does not warrant that the hardware will work properly in all environments and applications, and makes no warranty and representation, either implied or expressed, with respect to the quality, performance, merchantability, or fitness for a particular purpose.

PLANET has made every effort to ensure that this User's Manual is accurate; PLANET disclaims liability for any inaccuracies or omissions that may have occurred.

Information in this User's Manual is subject to change without notice and does not represent a commitment on the part of

PLANET. PLANET assumes no responsibility for any inaccuracies that may be contained in this User's Manual. PLANET makes no commitment to update or keep current the information in this User's Manual, and reserves the right to make improvements to this User's Manual and/or to the products described in this User's Manual, at any time without notice.

If you find information in this manual that is incorrect, misleading, or incomplete, we would appreciate your comments and suggestions.

## Trademarks

The PLANET logo is a trademark of PLANET Technology. This documentation may refer to numerous hardware and software products by their trade names. In most, if not all cases, these designations are claimed as trademarks or registered trademarks by their respective companies.

## Revision

User's Manual for PLANET Internet Camera

Model: ICA-100C-V2

Rev: 2.0 (December,2005)

Part No.EM-ICA100CV2

---

# **TABLE OF CONTENTS**

<b>ABOUT THIS GUIDE .....</b>	<b>5</b>
<b>CHAPTER 1 INTRODUCTION.....</b>	<b>6</b>
FEATURES AND BENEFITS .....	7
UNPACKING THE PACKAGE .....	9
SYSTEM REQUIREMENT.....	10
PHYSICAL DESCRIPTION.....	10
<b>CHAPTER 2 HARDWARE INSTALLATION .....</b>	<b>15</b>
ATTACHING THE CAMERA TO THE STAND .....	15
CONNECTING THE ETHERNET CABLE.....	16
ATTACHING THE POWER SUPPLY .....	16
<b>CHAPTER 3 SECURITY.....</b>	<b>17</b>
<b>CHAPTER 4 APPLICATION OF THE CAMERA..</b>	<b>18</b>
APPLICATIONS .....	19
APPLICATION DIAGRAMS OF THE CAMERA.....	20
<b>CHAPTER 5 USING THE CAMERA .....</b>	<b>22</b>
WEB CONFIGURATION.....	22
SYSTEM ADMINISTRATION .....	24
VIEW VIDEO – ACTIVEX MODE .....	44
VIEW IMAGE – JAVA MODE .....	45
<b>CHAPTER 6 IPVIEW PRO.....</b>	<b>47</b>
GETTING STARTED .....	47

USING IPVIEW PRO .....	51
CONFIGURING THE SYSTEM .....	56
<b>CHAPTER 7 APPENDIX .....</b>	<b>70</b>
<b>A FREQUENTLY ASKED QUESTIONS.....</b>	<b>70</b>
<b>B PING YOUR IP ADDRESS.....</b>	<b>73</b>
<b>C TROUBLE SHOOTING.....</b>	<b>74</b>
<b>D TIME ZONE TABLE .....</b>	<b>78</b>
<b>E XPLUG CONTROL INSTALLATION .....</b>	<b>80</b>
<b>F ADJUST INTERNET CAMERA FOCUS.....</b>	<b>84</b>
<b>G SPECIFICATION .....</b>	<b>85</b>
<b>H GLOSSARY OF TERMS.....</b>	<b>87</b>

---

# ***ABOUT THIS GUIDE***

This manual provides instructions and illustrations on how to use your ICA-100C Internet Camera, includes:

- Chapter 1, **Introduction**, provides the general information on the camera.
- Chapter 2, **Hardware Installation**, describes the hardware installation procedure for the camera.
- Chapter 3, **Security**, explains the security feature of the camera.
- Chapter 4, **Application of the Camera**, provides the illustrations of the camera's applications.
- Chapter 5, **Using the Camera**, guides you through the configuration using the web browser.
- Chapter 6, **IPView Pro**, helps you to install and use the software.
- Chapter 7, **Appendix**.

Please note that the illustrations or setting values in this manual are **FOR YOUR REFERENCE ONLY**. The actual settings and values depend on your system and network. If you are not sure about the respective information, please ask your network administrator or MIS staff for help.

---

## Chapter 1 INTRODUCTION

Thank you for purchasing the ICA-100C Internet Camera, a camera device that can be connected directly to an Ethernet or Fast Ethernet network. Compared to the conventional PC Camera, the Internet Camera features a built-in CPU and web-based solutions that can provide a cost-effective solution to transmit real-time high-quality video images and sounds for monitoring. The Internet Camera can be managed remotely, accessed and controlled from any PC/Notebook over the Intranet or Internet via a web browser.

The simple installation procedures and web-based interface allow you to integrate it into your network easily. The camera features **Power over Ethernet (PoE)** technology, allowing you to install and use it in an environment where is without power supply. In addition, with comprehensive applications supported, the Internet Camera is your best solution for remote monitor, high quality, and high performance video images.

---

# Features and Benefits

---

## ***Simple To Use***

The Internet Camera is a standalone system with built-in CPU requiring no special hardware or software such as PC frame grabber cards. The Internet Camera supports both ActiveX mode (for Internet Explorer users) and Java mode (for Internet Explorer and Netscape Navigator users). Therefore, all that is required is a web browser software such as Internet Explorer 5.0 or above or Netscape 6.0 or above. Just plug and view the picture from your Internet Camera with a valid IP Address.

## ***Support Variety of Platforms***

The ICA-100C supports TCP/IP networking, SMTP e-mail, HTTP and other Internet related protocols, and can be utilized in a mixed operating system environment such as Windows, UNIX, and Mac. It can be integrated easily into other www/Intranet applications.

## ***Web Configuration***

Applying a standard web browser, the administrator can configure and manage the Internet Camera directly from its own web page via the Intranet or Internet. Up to 64 users name and password are permitted with privilege setting controlled by the administrator.



## ***Remote Utility***

The powerful IPView Pro application assigns the administrator with a pre-defined user ID and password, allowing the administrator to modify the Internet Camera settings from the remote site via Intranet or Internet. When new firmware is available, you can also upgrade remotely over the network for added convenience. Users are also allowed to monitor the image, and take snapshots.

## ***Broad Range of Applications***

With today's high-speed Internet services, the Internet Camera can provide the ideal solution for live video images over the Intranet and Internet for remote monitoring. The Internet Camera allows remote access from a web browser for live image viewing and allows administrator to manage and control the Internet Camera anywhere and any time in the world. Apply the Internet Camera to monitor various objects and places such as homes, offices, banks, hospitals, child-care centers, amusement parks and other varieties of industrial and public monitoring. The Internet Camera can also be used for intruder detection; in addition, it can capture still images for archiving and many more applications.

---

# Unpacking the Package

---

Unpack the package and check all the items carefully. In addition to this *User's Guide*, be certain that you have:

- PLANET Internet Camera x 1
- Installation CD-ROM x 1
- Quick Installation Guide x 1
- Power Adapter x 1
- Camera Stand x 1
- RJ-45 Ethernet Cable x 1

If any item contained is damaged or missing, please contact your local dealer immediately. Also, keep the box and packing materials in case you need to ship the unit in the future.

---

# System Requirement

---

## ***Networking***

- 10Base-T Ethernet or 100Base-TX Fast Ethernet.

## ***Accessing the Camera***

### **For Web Browser Users**

- Operating System: Microsoft® Windows® 98SE/ME/2000/XP
- CPU: Intel Celeron 1.1GHz or above (Intel Pentium 4 is preferred)
- Memory Size: 32MB (64MB recommended)
- Resolution: 800x600 or above
- Internet Explorer 5.0 or above (ActiveX & JAVA Mode – Image View for Windows OS and JAVA Mode – Image View for other OS)  
Netscape 6.0 or above (JAVA Mode – Image View)

### **For IPView Pro Application Users**

- Operating System: Microsoft® Windows® 98SE/ME/2000/XP.
- CPU: CPU: Intel Celeron 1.1GHz or above (Intel Pentium 4 is preferred)
- Memory Size: 256MB (512 MB recommended)
- Resolution: 1024x768 or above

---

# Physical Description

---

This section describes the externally visible features of the Internet Camera.

## ***Front Panel***

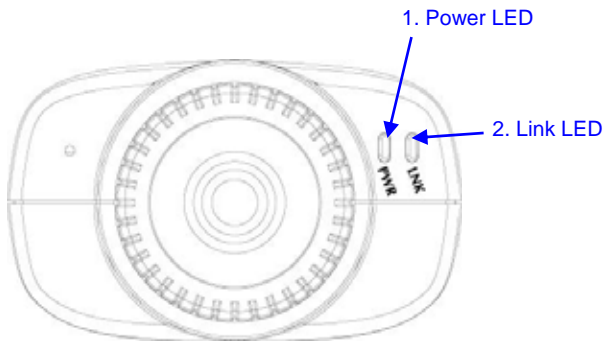

### **1. Power LED**

The Power LED is positioned on the right side of the Internet Camera's lens while facing the Internet Camera.

A steady **BLUE** light confirms that the Internet Camera is powered on.

### **2. Link LED**

The Link LED is positioned on the right side of the Internet Camera's lens while facing the Internet Camera. It is located right of the Power LED

A steady **ORANGE** light confirms that the camera has good connection to LAN connectivity.

Dependent on the data traffic the LED will begin to flash to indicate that the Internet Camera is receiving/sending data from/to the network.

## ***Rear Panel***

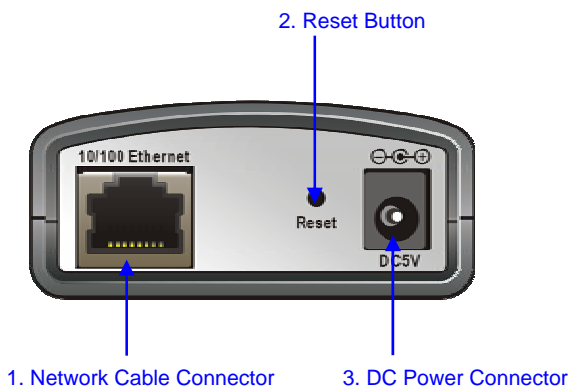

### **1. Network Cable Connector**

The Internet Camera's rear panel features an RJ-45 connector for connections to 10Base-T Ethernet cabling or 100Base-TX Fast Ethernet cabling (which should be Category 5 twisted-pair cable). The port supports the N-Way protocol, allowing the Internet Camera to automatically detect or negotiate the transmission speed of the network.

## **2. Reset Button**

Reset will be initiated when the reset button is pressed once, and Power LED begins to flash.

Factory Reset will be initiated when the reset button is pressed continuously for three seconds or when Power LED begins to light up. Release the reset button and the Power LED will begin to flash, indicating the Internet Camera is changing to factory reset. The IP address will return to the default setting as *192.168.0.20*.

## **3. DC Power Connector**

The DC power input connector is located on the Internet Camera's rear panel, and is labeled DC5V with a single jack socket to supply power to the Internet Camera. Power will be generated when the power supply is connected to a wall outlet.

# ***Top Panel***

## **Top Panel**

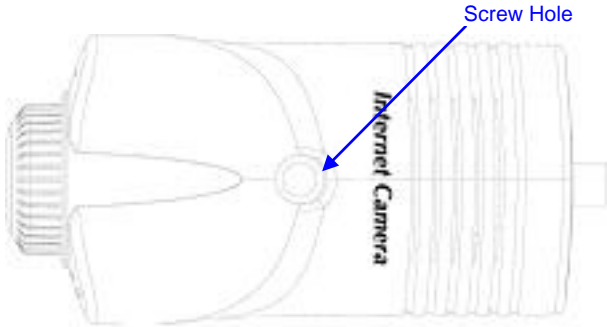

## **Screw Hole**

Located on the top/bottom panel of the camera, the screw hole is used to connect the camera stand onto the camera by attaching the screw head on the camera stand into the screw hole of the camera.

---

## Chapter 2 HARDWARE INSTALLATION

---

---

### Attaching the Camera to the Stand

---

The Internet Camera comes with a camera stand (optional) with a swivel ball screw head that can be attached to the Internet Camera's bottom screw hole. Attach the camera stand to the Internet Camera and station it for your application. There are three holes located in the base of the camera stand allowing the Internet Camera to be mounted on the ceiling or any wall securely.

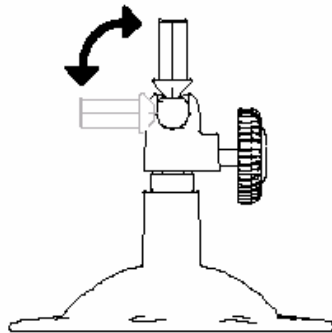



---

## Connecting the Ethernet cable

---

Connect an Ethernet cable to the network cable connector located on the Internet Camera's rear panel, and then attach it to the network.



---

## Attaching the Power Supply

---

Attach the external power supply to the DC power input connector located on Internet Camera's rear panel, and then connect it to your local power supply.



**TIP:** You can confirm power source is supplied from the LED indicators label Power on the Internet Camera is illuminated.

# 3

---

## Chapter 3 SECURITY

To ensure the highest security and prevent unauthorized usage of the Internet Camera the Administrator has the exclusive privilege to access the System Administration for settings and control requirements to allow users the level of entry and authorize the privileges for all users. The Internet Camera supports multi-level password protection and access to the Internet Camera is strictly restricted to defined user who has a “User Name” and “User Password” that is assigned by the Administrator.

The administrator can release a public user name and password so when remote users access the Internet Camera they will have the right to view the images transmitted by the Internet Camera.

**NOTE:** *Since the default settings are Null String, it is highly recommended to set the "Admin ID" and "Admin Password" when you are the first time to use the Internet Camera. Once the ID and Password are defined, only the administrator has the access to management the Internet Camera. This procedure should be done as soon as possible since the security features with the Internet Camera will not be enabled until the "Admin ID" and "Admin Password" is defined.*

# 4

---

## Chapter 4 APPLICATION OF THE CAMERA

The Internet Camera can be applied in wide variety of applications. With the built-in CPU, it can work as a standalone system that provides a web-based solution transmitting high quality video images and sounds for monitoring purposes. It can be managed remotely, accessed and controlled from any PC desktop over the Intranet or Internet via a web browser. With the easy installation procedure, real-time live images will be available. In addition, once the Internet Camera is installed coupled with the IPView Pro application, you can further expand the scope of the Internet Camera.

The following section will provide the typical applications for the Internet Camera along with the IPView Pro application, and also includes some basic knowledge to assist in the installation and configuration of the Internet Camera.

---

# Applications

---

- Monitoring of local and remote places and objects such as construction sites, hospitals, amusement parks, schools and day-care centers through the use of a web browser.
- Capture multiple frame images from the IPView pro application.
- Configure the camera to upload image or send-mail messages with a single frame image.

---

# Application Diagrams of the Camera

---

## *Home Applications*



# Office Applications



# 5

---

## Chapter 5 USING THE CAMERA

You can access and manage the Internet Camera through: 1) a web browser, and 2) the enclosed software IPView Pro. This chapter describes the Web Configuration Utility, and provides the instructions on using the camera with a web browser.

---

### Web Configuration

---

The Internet Camera must be configured through its built-in Web-based Configuration. (*Extensive knowledge of LAN will be helpful in setting up the Internet Camera.*)

From the web browser, enter the default IP address to access the Welcome screen of the Internet Camera. To configure your Internet Camera, type ***http://192.168.0.20*** in the address box. The number is the default IP address of your Internet Camera. Then, press [Enter].

**NOTE:** *The computer's IP address must correspond with the camera's IP address in the same segment for the two devices to communicate.*



***Welcome Screen of the Configuration Utility***

After the default IP address is entered from the browser, the Internet Camera Welcome screen will appear with a still image. There will be three options to choose from to set-up and view your Internet Camera, including:

- **View Video – ActiveX Mode**
- **View Video – Java Mode**
- **System Administration**



---

# System Administration

---

Under the Welcome screen of the Configuration Utility, click **System Administration** to enter the administration window that contains the settings required for the camera in the top menu bar, including **Management**, **Configuration**, **Tools**, **Help**, and **Home**.

***TIP:** Once you have changed the settings in each option, click **Save** to store the settings, or **Cancel** to abandon, or **Refresh** to reload the status. During the configuration, whenever you click **Home** in the top menu bar will make you return to the Welcome window.*

## System Administration → Management

The Management window contains the information of your configuration. Click the items in the left column to view your settings, including: **System**, **Video**, **Network**, and **User**.



## System

Click the **System** item in the left column to display the device status of your camera.

Device Status	
Camera Name	PL-701EA5
Location	
Model	ICA-100PE
Firmware Version	3.09 (2005-04-18)
MAC Address	00 30 4F 00 ED C6
IP Address	192.168.0.28

Ethernet Status	
Link	Yes
Speed	100Mbps
Duplex	Full Duplex

- **Device Status:** The information about the camera, including the Camera Name, Location, Model, Firmware Version, MAC Address and IP Address, can be found in this field.
- **Ethernet Status:** You can monitor the networking status in this field, including the Link (network connection), Speed, and the Duplex mode.

## Video

Click the **Video** item in the left column to display the video configuration of your camera.

Video Status	
Video Resolution	: 320 X 240
Compression Rate	: Medium
Frame Rate	: Auto
Frame Size	: 7904 Bytes
Light Frequency	: 60 Hz

- **Video Status:** The video configuration about the camera, including the Video Resolution, Compression Rate,

Frame Rate, Frame Size and IP Address, can be found in this field.

## Network

Click the **Network** item in the left column to display the information of the LAN.

Network Status	
IP Address	: 192.168.0.20
Subnet Mask	: 255.255.255.0
Default Gateway	: 0.0.0.0
Primary DNS Address	: 0.0.0.0
Secondary DNS Address	: 0.0.0.0
Dynamic DNS	: Disable
Secondary HTTP Port	: Disable (Port: 81)
UPnP	: Enable (IP: 0.0.0.0)
<input type="button" value="Refresh"/>	

- **Network Status:** The items in this field display the information of the LAN, such as the IP Address, Subnet Mask, Default Gateway, Primary DNS Address, Secondary DNS Address, Dynamic DNS, Secondary HTTP Port, and UPnP.

## User

Click the **User** item in the left column to display the user(s) information.

Active Users		
IP	Name	DateTime
<input type="button" value="Refresh"/>		

- **Active Users:** The items in this field display the user(s) information, including the user(s) IP address, Name, and DateTime.

## System Administration → Configuration

The **Configuration** window contains commands for settings that are required to input key details to setup the camera for operation. Click **Configuration** in the top menu bar and the Configuration window will appear as below:



## System

Click the **System** item in the left column to setup the basic configuration of your camera.

System Setting	
Camera Name	: PL701EA5
Location	: <input type="text"/>
Admin	: Admin ID : <input type="text"/>
	: Admin Password : <input type="text"/>
	: Confirm Again : <input type="text"/>
LED Control	: <input checked="" type="radio"/> Normal <input type="radio"/> OFF <input type="radio"/> Dummy
<input type="button" value="Save"/> <input type="button" value="Cancel"/>	

- **System Setting:** In this field, you can configure the basic information of your camera.

- **Camera Name:** This field is used to enter a descriptive name for the device. The default setting for the Camera Name is *PL-xxxxxx*, where *xxxxxx* is the last six digit of the MAC Address. The maximum length is 32 (printable ASCII).
- **Location:** This field is used to enter a descriptive name for the location used by the camera (optional).
- **Admin:** This field is used to enter the administrator name along with the password to access the System Administration settings. Be sure to enter the password twice to confirm the details once in the *Admin Password* field and again in the *Confirm Password* field.

The default setting for administrator is blank space (Null String), and you need to key in the administrator name with a maximum length of 12 (printable ASCII) characters and enter the administrator password with a maximum length of 8 (printable ASCII) characters.

It is highly recommended to set the Admin ID and Admin Password as soon as possible to enable security option for the Internet Camera to function.

- **LED Control:** This option allows user to setup the LED illumination as desired. This feature provides the flexibility when surveillance activity is ON.

There are three options as follows:

<b>Normal</b>	Power - Steady On of the LED indicator. Link - Steady On of the LED indicator. When LAN activity is present the LED indicator will flash steadily.
<b>OFF</b>	Power - LED indicator is off. Link - LED indicator is off.
<b>Dummy</b>	Power - Steady On of the LED indicator. Link - Steady On of the LED indicator with random flashing.

The default setting for the LED control is at *Normal*. When you have configured the LED control, the correct illumination will be set after 1 minute.

## Video

Click the **Video** item in the left column to setup the image configuration of your camera.

**Video Setting**

Video Resolution :  160 x 120  320 x 240  640 x 480

Compression Rate :  Very Low  Low  Medium  High  Very High

Frame Rate :  1  5  7  15  20  Auto (Frames/Sec)

Brightness Control :

Contrast Control :

Saturation Control :

Light Frequency :  50 Hz  60 Hz

Mirror :  Horizontal Mirror  Vertical Mirror

Anti-Flicker :

- **Video Setting:** In this field, you can configure the basic information of your camera.
  - **Video Resolution:** Select the desired video resolution format, including *160x120*, *320x240* (default) and *640x480*.
  - **Compression Rate:** Select the desired compression rate with five levels from *Very Low* to *Very High*. Higher video compression rate will generate more

compact file size with less video quality and vice-versa. The default setting is *Medium*.

- **Frame Rate:** Select the frame rate desired with default setting at *Auto* for optimal frame rate.
- **Brightness Control:** Adjust the brightness level with default setting at *64*.
- **Contrast Control:** Adjust the contrast level with default setting at *64*.
- **Saturation Control:** Adjust the saturation with default setting at *64*.
- **Light Frequency:** Adjust the light frequency to suit your area of operation from the options either *50 Hz* or *60 Hz* (default).
- **Mirror:** Select **Horizontal Mirror** to display the image in a horizontal mirror mode, or **Vertical Mirror** to display the image in a vertical mirror mode.
- **Anti-Flicker:** If you capture a flicker image because of the environment factor (for example, high light of lamp), please select this item to solve this problem.

## **Network**

Click the **Network** item in the left column to setup the LAN configuration of your camera.

**TCP/IP**

IP Address Mode :  Fixed IP

IP Address : 192.168.0.20

Subnet Mask : 255.255.255.0

Default Gateway : 0.0.0.0

Dynamic IP (DHCP)

PPPoE

User ID :

Password :

DNS IP Address : 1. 0.0.0.0

2. 0.0.0.0

Dynamic DNS :  Enable  Disable

Service Provider : DynDNS.org

Host Name :

User Name/E-mail :

Password/Key :

Second HTTP Port :  Enable  Disable

Port Number : 81

UPnP :  Enable  Disable

## - TCP/IP:

- **IP Address Mode:** This field provides your with three options to select the IP Address Mode:

**Fixed IP** – You can select this option and enter the IP address directly. The default settings are:

- IP Address – 192.168.0.20
- Subnet Mask – 255.255.255.0
- Default Gateway – 0.0.0.0

**Dynamic Address (DHCP)** – If your network uses the DHCP server, select this option. According to this setting, the camera will be assigned an IP address from the DHCP server automatically. Every time when the camera starts up, please make sure that the DHCP server is set to assign a static IP address to your camera.



**PPPoE** – If your application requires a direct connection from an ADSL modem through the camera's RJ-45 LAN port, click this option and enter the User ID and Password into the respective boxes. (*You should have an ISP PPPoE account.*) The camera will get an IP address from the ISP as starting up.

- **DNS IP Address:** DNS (Domain Name System) server is an Internet service that translates domain names into IP addresses. Enter at least one DNS IP Address in this field.
- **Dynamic DNS:** The Dynamic DNS service allows you to alias a dynamic IP address to a static hostname in any of the domains, allowing your computer to be more easily accessed from various locations on the Internet.
- **Second HTTP Port:** The default port for communication is via port 80, and you can change it according to your network configuration. Select **Enable** from the option and enter the desired port number in the following box.
- **UPnP:** UPnP is the architecture for pervasive peer-to-peer network connectivity of intelligent appliances and PCs of all form factors. Check the **Enable** option to enable the function of your camera.

## **User**

Click the **User** item in the left column to add, edit and delete users for your camera.

**User Access Control**

Access Control :  Enable  Disable

**Define Users**

Add User : User Name :

User Password :

Upload/E-mail Video :  Yes  No

Delete User :

User List : %%UserTable%%

Name	Upload/E-mail Video

- **User Access Control:**

- **Access Control:** The administrator has the authority to give permission for the privilege to control the device to users by selecting *Enable* or *Disable*. The default setting is *No*.

- **Define Users:** Use this field to add or delete users for your camera.

- **Add User:** Enter the user name in this box, and enter the user's password assigned by the administrator. The maximum password length is 8 (printable ASCII). The administrator has the authority to give permission for the privilege to control the **Upload/E-mail Video** control to the users by selecting *Yes* or *No* to activate the **Upload/E-mail Video**.

To add a new user's name, enter the necessary information first and click the **Add** button.

- **Delete User:** Select the user you want to delete from the pull-down menu, and then click the **Delete** button.
- **User List:** This list displays the current users status of your camera.

## DateTime

Click the **DateTime** item in the left column to setup time and date for your camera, providing correct information for the remote users who might be thousands of miles away from the camera's location.

**Date & Time Setting**

Date & Time :

Synchronized with Time Server

IP Address :

Protocol :  NTP  Time

TimeZone : + 0 Hours

Set Manually

Date :  (Example : 2004-09-01)

Time :  (Example : 06:12:35)

- **Date & Time:** You can set up time and date manually or automatically by selecting the *Synchronized with Time Server* option.
- **Synchronized with Time Server:** Select this option and the time will be based on GMT setting. The time will be synchronized every 10 minutes. When selecting this option, you have to enter the required information in the following fields:
  - IP Address** – Enter the IP Address of the Time Server in this box.
  - Protocol** – Two options of NTP or Time are available for your selection to link with the Time Server. The default setting is NTP.
  - TimeZone** – Select the time zone for the region from the pull-down menu.
- **Set Manually:** Select this option to set the time manually. The system administrator must enter the date and time in the respective field manually.

## Upload

Click the **Upload** item in the left column to setup configuration for FTP server, time schedule and manual operation.

The screenshot shows a configuration window with three main sections: FTP Server, Time Schedule, and Manual Operation. The FTP Server section includes fields for Host Address, Port Number (set to 21), User Name, Password, Directory Path, and Passive Mode (Yes/No). The Time Schedule section has an 'Enable upload video to FTP server' checkbox, radio buttons for 'Always' (selected) and 'Schedule', a 'Day' selector (Monday to Sunday), 'Start' and 'Stop' time fields (00.00), 'Video Frequency' dropdown (set to 1 Frames/Second), and a 'Base File Name' field. The Manual Operation section also has an 'Enable upload video to FTP server' checkbox, a 'Base File Name' field, and radio buttons for 'File' options: 'Override' (selected), 'Date/Time Suffix', and 'Sequence Number Suffix Up to' (set to 1024). 'Save' and 'Cancel' buttons are at the bottom.

- **FTP Server:** This field contains the following six basic settings for your FTP server.
  - **Host Address:** The IP Address of the target FTP server.
  - **Port Number:** The standard port number for the FTP server is Port **21**, and it's also the default setting. If the FTP server uses a specific port, please confirm the IT manager.
  - **User Name:** Enter the user name in this field.
  - **Password:** Enter the user password in this field to login the FTP server.

- **Directory Path:** Enter an existing folder name in this field, and the images will be uploaded to the given folder.
- **Passive Mode:** This function depends on your FTP server. Please check with your IT manager if the FTP server uses passive mode. The default setting is *No*.
- **Time Schedule:** Select the “*Enable upload video to FTP server*” option and enter the relevant information, such as the schedule, video frequency and base file name.
  - **Schedule:** You can 1.) Choose *Always* to always upload the video to FTP server, or 2.) Set the *Schedule* to manage the uploading task. In the Schedule option, you can set the *Day* and *Time Period* option.
  - **Video Frequency:** There are two ways to set the video frequency: 1.) Set *Auto/1/2/3* frames per second, or 2.) Set the time in seconds for every frame.
  - **Base File Name:** Enter the file name to make sure that the images could be saved as the base file name.
  - **File:** Since you may not upload only one image to the FTP server, you can choose the filing rule, including *Overwrite*, *Date/Time Suffix*, and set up the *Sequence Number*.
- **Manual Operation:** When you click the **Upload Video** button in view video screen, it will start to upload the image. The setting refers to *Base File Name* and *File* information above.

## E-mail

Click the **E-mail** item in the left column to setup configuration for E-mail account, time schedule and manual operation settings.

E-mail Account	
SMTP Server Address	<input type="text"/>
Sender e-mail Address	<input type="text"/>
Receiver e-mail Address	<input type="text"/>
User Name	<input type="text"/>
Password	<input type="text"/>
Time Schedule	
Time Schedule	<input type="checkbox"/> Enable e-mail video to e-mail account
	<input checked="" type="radio"/> Always <input type="radio"/> Schedule
Day	<input type="checkbox"/> Mon <input type="checkbox"/> Tue <input type="checkbox"/> Wed <input type="checkbox"/> Thu <input type="checkbox"/> Fri <input type="checkbox"/> Sat <input type="checkbox"/> Sun
Time Period	Start: <input type="text"/> (Example : 06:30:00)
	Stop: <input type="text"/> (Example : 22:30:00)
Interval	: <input type="text"/> Seconds
Manual Operation	
Manual Operation	<input type="checkbox"/> Enable e-mail video to e-mail account
Interval	: <input type="text"/> Seconds
<input type="button" value="Save"/> <input type="button" value="Cancel"/>	

- **E-mail Account:** This field contains the following six basic settings for your FTP server.
  - **SMTP Server Address:** SMTP (Simple Mail Transfer Protocol) is a protocol for sending e-mail messages between servers you need to input the mail server address in this field.
  - **Sender e-mail Address:** Enter the e-mail address of the user who will send the e-mail.
  - **Receiver e-mail Address:** Enter the e-mail address of the user who will receive the e-mail.
  - **User Name:** Enter the user name in this field.
  - **Password:** Enter the user password in this field to login receiver's mail server.
- **Time Schedule:** Select the “*Enable-mail video to e-mail account*” option to set schedule to send e-mail. Please refer to the instruction in “**Upload**” section. The

**Interval** option is to define time interval between two images sent.

- **Manual Operation:** When you click the **E-mail Video** button in view video screen, it will start to e-mail image. The **Interval** option is to define time interval between two images sent.

## **System Administration → Tools**

The **Tools** window contains commands for restarting the camera. Click **Tools** in the top menu bar and the Tools window will appear as below:



## E-mail Test

Click the **E-mail Test** item in the left column to test your e-mail account.

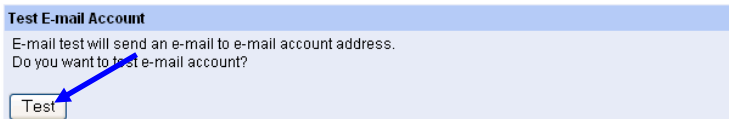

- **Test E-mail Account:** Click the **Test** button to test the e-mail account you provided.

## Reset

Do you really want to reset this device? Click the **YES** button from this option, and you can restart the camera just like turning the device off and on and saved settings are retained. If you do



not want to reset the camera, exit this window without clicking **YES**.



## **Factory Reset**

Do you really want to factory reset this device? Click the **YES** button from this option, and you can resume all factory default settings for the camera. If you do not want to restore the factory settings, exit this window without clicking **YES**. Please NOTE that you have to configure the network settings again after a Factory Reset.

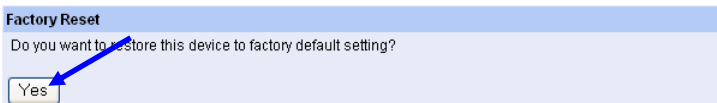

## **Firmware Upgrade**

When new firmware is available, you can upgrade it through this window. Click the **Browse...** button to point to the firmware file, and then click **Update** to start upgrading.

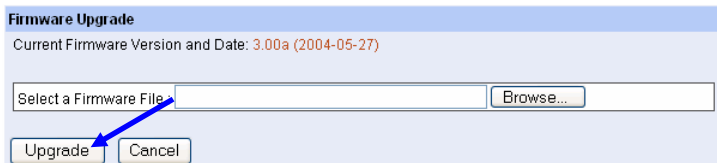

## **Backup**

Click the **Backup** item in the left column to backup the current configuration.

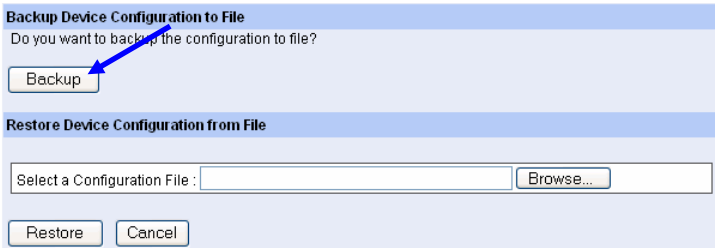

- **Backup Device Configuration to File:** Do you really want to backup the configuration to file? Click the **Backup** button from this option, and you can save the current configuration to file.
- **Restore Device Configuration from File:** You can resume the device configuration from saved file in the computer. Click the **Browse...** button to point to the file, and then click **Restore** to start restoring.

## ***System Administration → Help***

The **Help** window provides the basic information of the camera. Click **Help** in the top menu bar and the Help window will appear as below:



## **About**

Displays the camera's model name and version.

Once the configuration is completed, click **Home** to return to the Welcome screen and select the desired View Video option either through **ActiveX Mode** or **Java Mode** as described in the next section.

Then, position the camera to the desired location appropriately for your purpose. Followed by adjustment of the camera focus, done manually by turning the lens clockwise or anti-clockwise to the desired image quality. Please refer to *Appendix F* for detailed instruction.

---

## View Video – ActiveX Mode

---

To view video images from the browser, click **View Image – ActiveX Mode** from the Welcome screen to access the video images from Internet Explorer as illustrated below:



**Camera Name:** The Camera name will be displayed when the Camera Name field is entered in the Web Configuration setting under **Configuration**.

**Date and Time:** The date/time of the camera will be displayed here.

In the **View Video – ActiveX Mode**, you are allowed to use the **Upload Video** and **E-mail Video** options. Simply click the

desired selection **ON** or **OFF** to utilize the options for each of the functions.

---

## View Image – Java Mode

---

To view video images from the browser, click **View Image – Java Mode** from the Welcome screen to access the video images from Internet Explorer or Netscape browser as illustrated below:



**Camera Name:** The Camera name will be displayed when the Camera Name field is entered in the Web Configuration setting under **Configuration**.

**Date and Time:** The date/time of the camera will be displayed here.

In the **View Video – Java Mode**, you are allowed to use the **Upload Video** and **E-mail Video** options. Simply click the desired selection **ON** or **OFF** to utilize the options for each of the functions.

**NOTE:**

1. Please refer to the appendix on how to install ActiveX, including 1.) install to the Web Server, and 2.) install to your Local PC.
2. The administrator has the authority to set the upload video function through the setting in the **Upload** option under **Configuration**.
3. The administrator has the authority to set the e-mail video function through the setting in the **E-mail** option under **Configuration**.

# 6

---

## Chapter 6 IPVIEW PRO

This chapter describes the IPView Pro, which is a powerful software application designed with a user-friendly interface for ease of control and navigation requirements.

---

### Getting Started

---

To launch IPView Pro, click **Start > Programs > PLANET > IPView Pro > IPView Pro**. The main screen will appear as below:

















*NOTE: IPView Pro requires the system's resolution setting up to 1024x768. Please configure the resolution to 1024x768 or higher; otherwise, it may show incomplete screen when launching the program.*

## **Item Feature**

<b>NO.</b>	<b>Item</b>	<b>Description</b>
<b>1</b>	Date/Time	Show current date/time.

<p>2</p>	<p>Status Mode Window</p>	<p>Show the camera's status in this window. Click the <b>Change Status Mode</b> button (  ) on the right lower corner of the window to change the display mode:</p> <div style="text-align: center;">  </div> <p>Camera list mode      Camera information mode</p>
<p>3</p>	<p>View Window</p>	<p>Show the camera's view in this window.</p>
<p>4</p>	<p>View Mode Buttons</p>	<p>Select the view mode from these buttons.</p> <ul style="list-style-type: none"> <li> Show one camera in View Window.</li> <li> Show four cameras in View Window.</li> <li> Show six cameras in View Window with the first one as the major view.</li> <li> Show eight cameras in View Window with the first one as the major view.</li> <li> Show nine cameras in View Window.</li> <li> Show ten cameras in View Window with the first two as the major views.</li> <li> Show thirteen cameras in View Window with the first one as the major view.</li> <li> Show sixteen cameras in View Window.</li> </ul> <hr/> <ul style="list-style-type: none"> <li> Show the selected camera in full screen view.</li> <li> Enable displaying the video views in circles.</li> </ul>

5	Key Lock Button	Click to lock/unlock the camera. When locked, the user cannot operate any camera.
6	Power Button	Click to exit or minimize IPView Pro.
7	Record Button	Record video clip of the selected camera and save it in the computer. The storage position can be configured in System Configuration. When you click the button, you can select <b>Manual Record</b> , <b>Schedule Record</b> , or <b>Motion Record</b> .
8	Play Button	Play the recorded video file in the computer.
9	System Configure	Click to enter the System Configuration.

---

# Using IPView Pro

---

## *Adding a Camera*

To add a camera:

1. Click the *System Configure* button to enter the System Configuration.

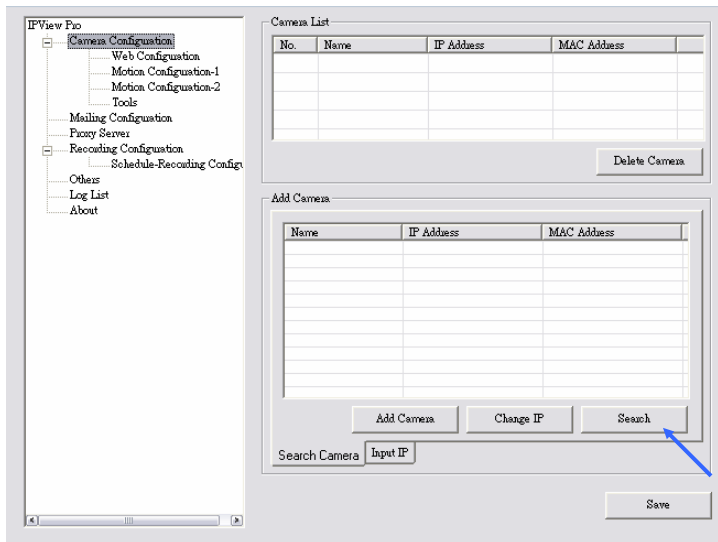

If you are not sure of the camera's IP address, you can click *Search* to search the available camera(s) within the network.

2. Select the camera you want by highlighting it, and then click *Add Camera*.

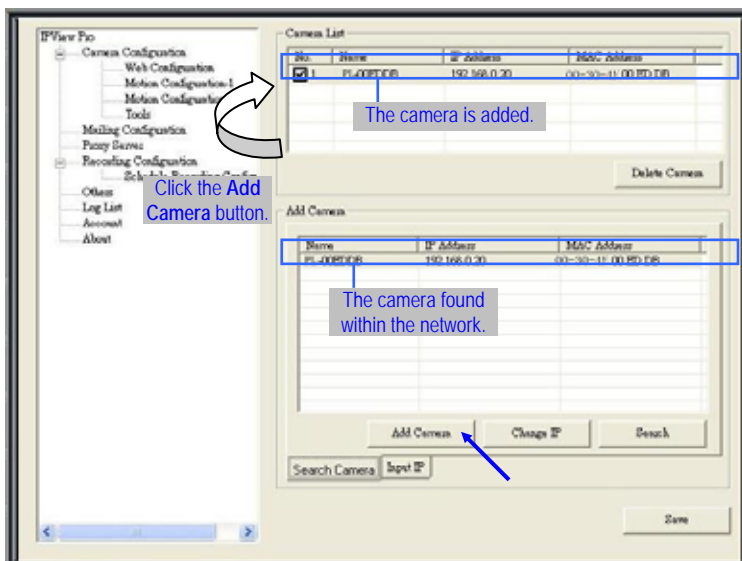

3. Click *Save*, and then click the **System Configure** button to return to View Window. The selected camera's video will be displayed now.

Alternately, you can add a camera by entering the its IP address directly:

4. Select the **Input IP** tab.

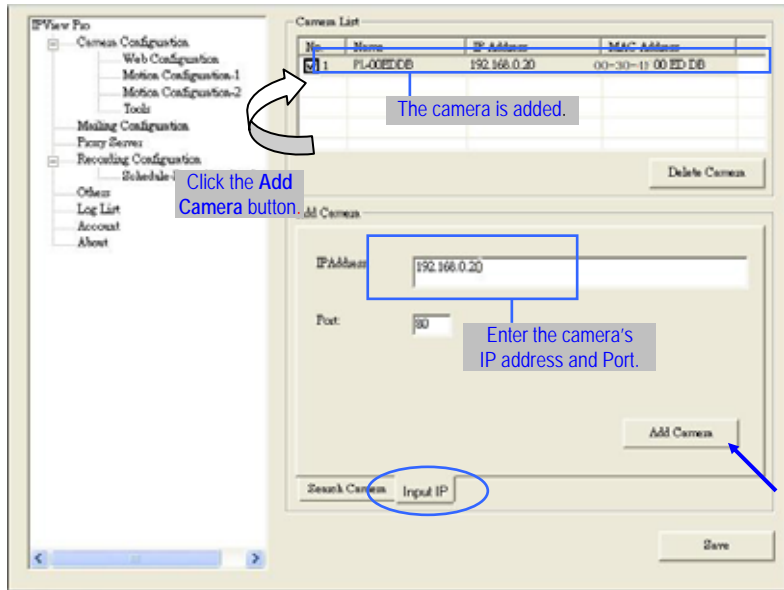

5. Enter the camera's IP address (default: 192.168.1.2) and Port (default: 80), and then click **Add Camera**.

6. Click **Save**, and then click the **System Configure** button to return to View Window. The selected camera's video will be displayed now.

## Removing a Camera

To remove the camera from the list:

1. Select the camera you want to remove.
2. Click *Delete Camera*.

## Viewing a Camera

From the View Modes of the panel, you can select one-camera mode or other modes to display your video. IPView Pro allows a maximum of 16 cameras for viewing.

For example, if you use only one camera, select one-camera mode (  ), and the View Window will display the view as *figure 1*.

If there are four cameras, select four-camera mode (  ), and the View Window will display the view as *figure 2*.



*Figure 1.*



*Figure 2.*

## Recording Video

IPView Pro allows you to record the video clip and save it in your computer through the following methods: **Manual Record**, **Schedule Record**, and **Motion Record**.

When you click the *Record* button and select **Manual Record**, it will start recording. Click the button again to stop. If you select **Schedule Record** or **Motion Record**, the system will record the video clip according to the settings in System Configuration.

## Playing Recorded Video

The recorded video clips are saved in your computer, and can be played using Windows Media Player. To start playback, simply click the *Play* button on the panel, and the following dialog screen will appear, allowing you to select the file to playback.

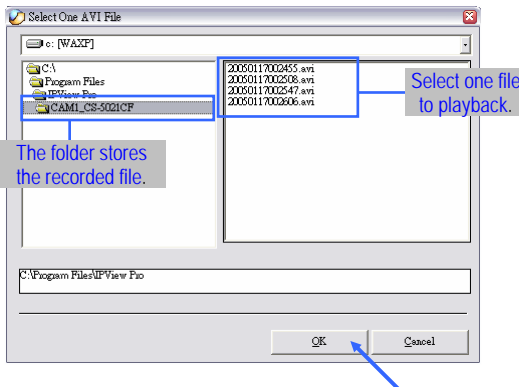

Select the recorded file in the computer, and then click *OK*.



---

# Configuring the System

---

Clicking the *System Configure* button on the panel allows you to configure the system settings, and the **System Configuration Screen** will appear in the View Window as shown below. Once configured, click *Save* to save the settings, and then click the *System Configure* button again to exit configuration.

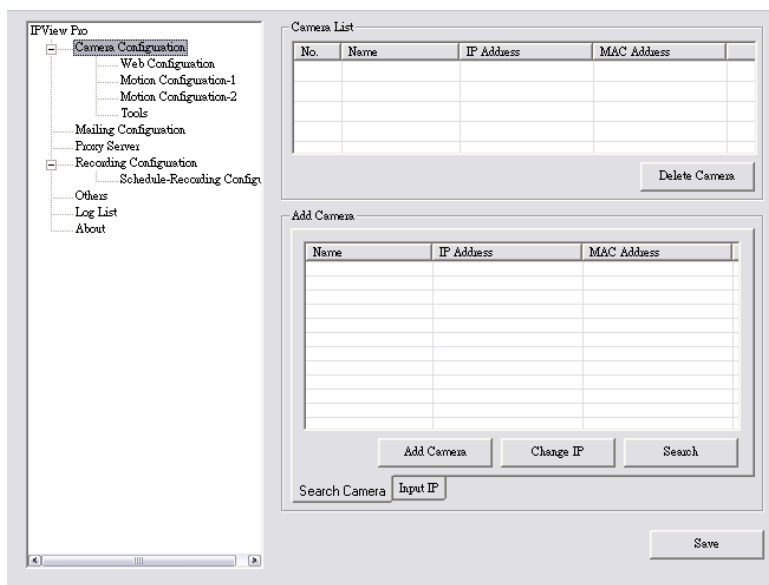

*System Configuration Screen*

## Camera Configuration

In this field, you can add/delete the camera (as described in the previous section). Also, you can configure the following settings:

### Web Configuration

In the left column, selecting the **Web Configuration** item will launch the Web Configuration Utility in View Window.



You can configure these settings according to the description in *Chapter 5, Using the Camera*. Click *Back* to exit the Web Configuration Utility.

## Motion Configuration-1

The **Motion Configuration-1** item provides the commands for motion detection control. Before configuring, you should select one camera from the pull-down menu.

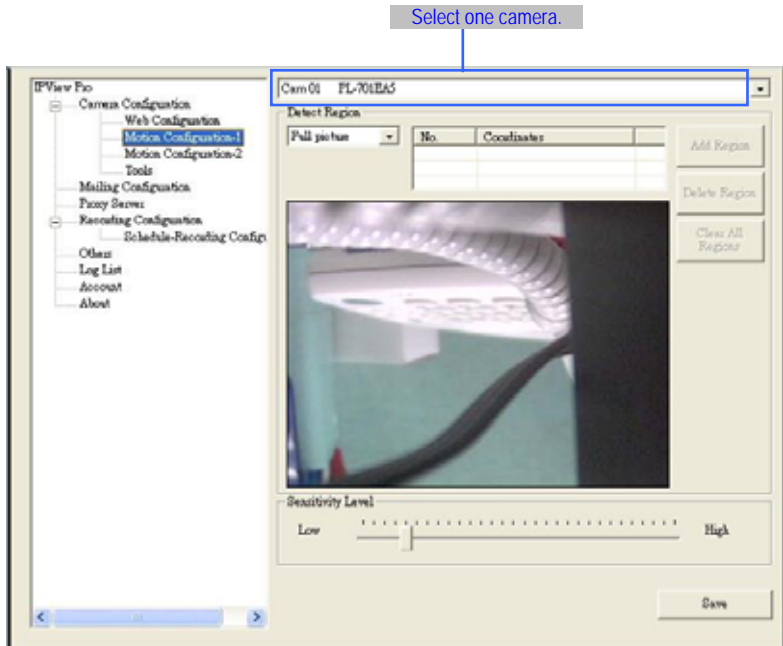

- **Detect Region:** When you select the **Full picture** option, the camera will monitor the whole area.
- **Sensitivity Level:** Move the slide bar to adjust the sensitivity level for detecting motion to record video.

## Motion Configuration-2

The **Motion Configuration-2** item allows you to configure to the alarm and e-mail setting.

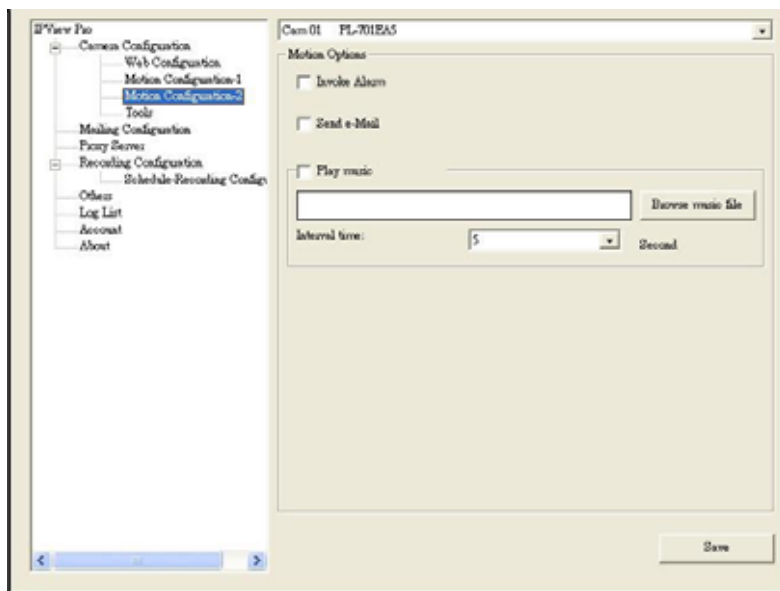

- **Invoke Alarm:** Select this option to enable alarm when some motion detected by the system.
- **Send e-mail:** When this option is checked, click the **Mailing Configuration** in the left column to enter the required information (see the following section).

## Tools

The **Tools** item allows you to reset the camera to factory default setting or upgrade the firmware.

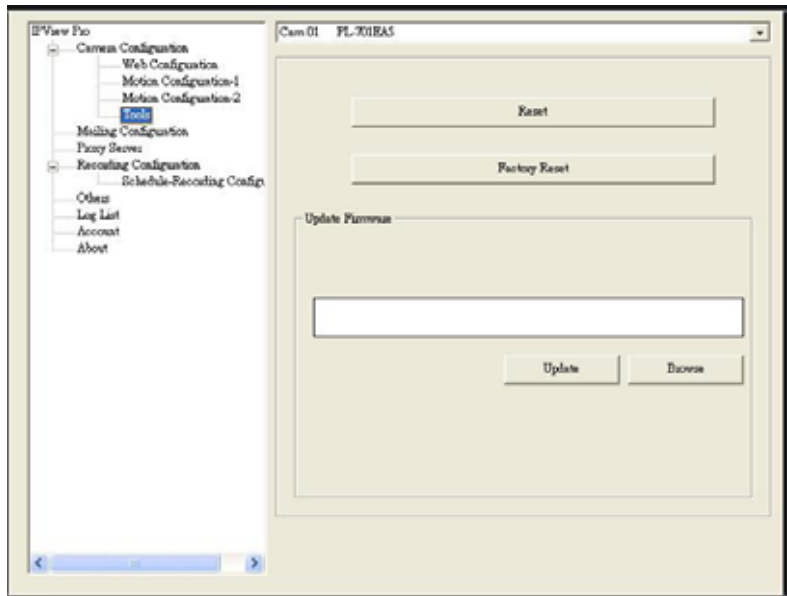

- **Reset:** Restore the original setting of your camera. Do you really want to reset this device? Click *Yes* in the pop-up dialog box to confirm.
- **Factory Reset:** Restore the factory default settings of the camera. Do you really want to factory reset this device? Click *Yes* in the pop-up dialog box to confirm.
- **Update Firmware:** When new firmware is available, you can upgrade it using this option. Click *Browse* to find the firmware file, and then click *Update*.

## Mailing Configuration

When Motion Detection function is enabled and the **Send e-mail** option is checked, you should enter the required information in the respective fields.

The screenshot shows the 'IPView Pro' application window. The left pane displays a tree view with the following items: Camera Configuration, Web Configuration, Motion Configuration-1, Motion Configuration-2, Tools, **Mailing Configuration** (selected), Proxy Server, Recording Configuration, Schedule-Recording Config, Others, Log List, and About. The right pane contains the following configuration fields:

- Mail Server:
- Mail From:
- Mail To:
- Subject:
- User Name:
- Password:
- Interval Time:  Second

A 'Save' button is located at the bottom right of the configuration area.

- **Mail Server:** Enter the mail server address that is used to send your e-mail.
- **Mail From/To:** Enter the sender's/receiver's e-mail address.
- **Subject:** Enter the title of the e-mail.
- **User Name/Password:** Enter the user name/password to login the mail server.
- **Interval Time:** Enter a number in this box to setup the time (in second) to send E-mail regularly.

## Proxy Server

Check the Proxy Server option and enter the required settings in the **Address** and **Port** boxes to enable and use the Proxy Server function.

The screenshot shows the IPView Pro configuration window. On the left is a tree view with the following items: Camera Configuration (sub-items: Web Configuration, Motion Configuration-1, Motion Configuration-2, Tools), Mailing Configuration, Proxy Server (highlighted), Recording Configuration (sub-item: Schedule-Recording Config), Others (sub-items: Log List, About), and a scrollbar at the bottom. On the right is the Proxy Server configuration panel, which includes a checkbox for 'Proxy Server', an 'Address' text box, a 'Port' text box containing '8080', and a checked checkbox for 'Bypass proxy server for local network addr.'. A 'Save' button is located at the bottom right of the window.

# Recording Configuration

In this field, you can configure the storage settings.

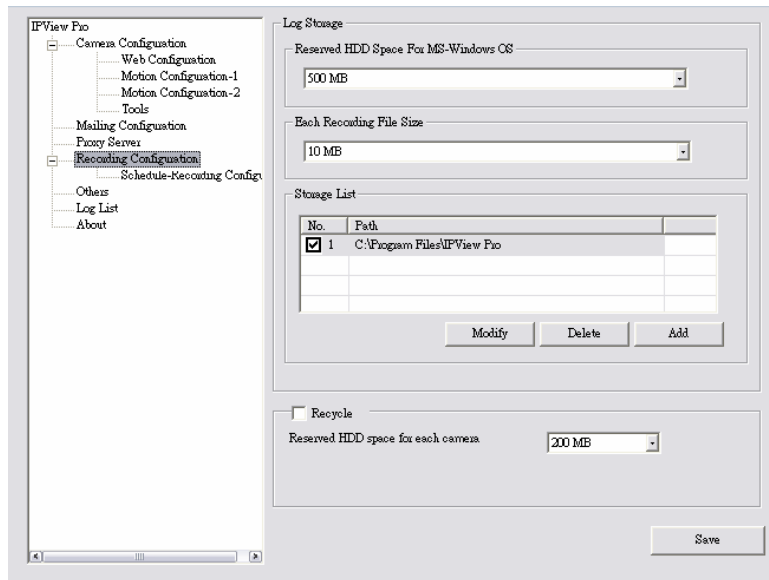

## - Log Storage:

- **Reserved HDD Space For MS-Windows OS** – You can reserve **500 MB to 1000 MB** hard disk space for the program.
- **Each Recording File Size** – If the recorded video files reach the file size limit, video images will be recorded into another file automatically. The available settings are from **10 MB to 50 MB**.



- **Storage List** – The destination folder to save the recorded video file can be specified here. Click *Modify* to change the current path setting; click *Add* to add a new destination folder; click *Delete* to remove a selected path setting. Please note that you are not allowed to delete a path setting if there is only one setting in the list.
- **Recycle:** You can check this option to clear the files when the unreserved space of your hard disk is filled. The available settings are from **200 MB** to **50000 MB**.

## Schedule-Recording Configuration

This recording function will work after you have enabled respective settings in the Schedule mode. The recording schedule can be defined by **Date Mode** or **Week Mode**.

- **Date Mode:** First, select the camera desired from the pull-down menu. Then, setup the time in the **Start/Stop** fields. Click **Add** to add the recording schedule to the list. Click **Save** to save the settings.

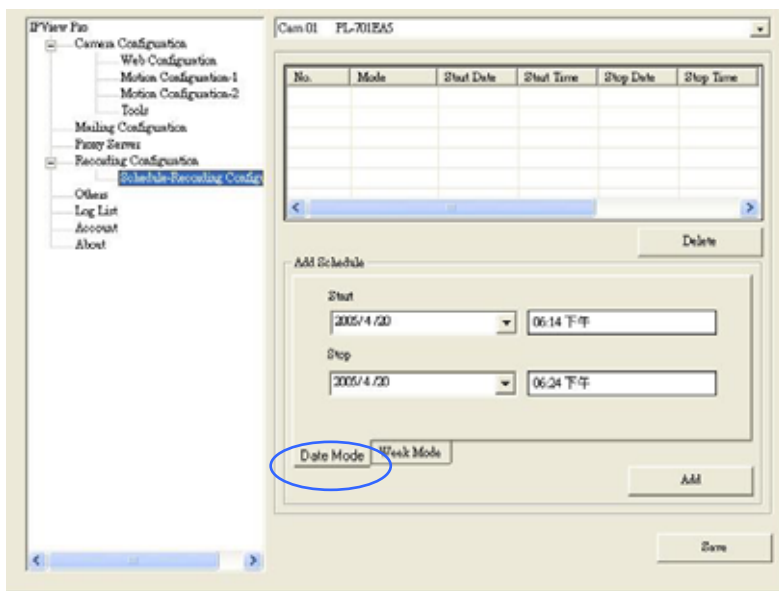

- **Week Mode:** First, select the camera desired from the pull-down menu. Then, setup the time in the **Start/Stop** fields, and select the weekday from the buttons. Click **Add** to add the recording schedule to the list. Click **Save** to save the settings.

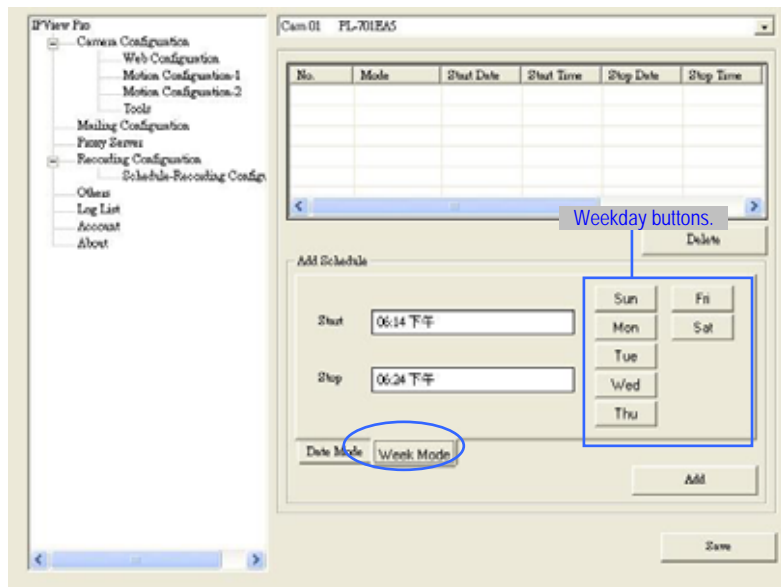

## Others

When multiple cameras connected, this option allows the system to display these views as the main view in circles according to your time settings. The range of **Time interval of scan** is from **1** to **20** seconds.

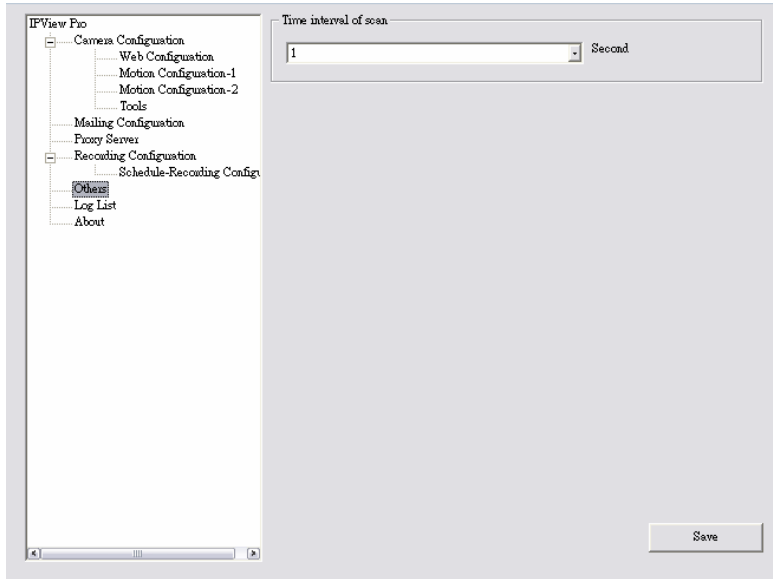

## Log List

This filed displays the user(s) information, which includes the Date, MAC address, and the brief description of events.

The screenshot shows a software interface with a left-hand navigation pane and a main content area. The navigation pane lists various configuration options such as Camera Configuration, Web Configuration, Motion Configuration-1, Motion Configuration-2, Tools, Mailing Configuration, Proxy Server, Recording Configuration, Schedule-Recording Config, Other, Log List, Account, and About. The main content area is titled 'Cam 01 FL701E65' and displays a table with the following data:

Date	IP Address	Event
2005/4/20 下午 05:40:02	192.168.0.20	Connection success
2005/4/20 下午 05:40:02	192.168.0.20	Image resolution has been changed.

## ***About***

This file provides information of the software application.

---

## Chapter 7 APPENDIX

---

---

### A Frequently Asked Questions

---

#### Internet Camera Features

**Q:** What is an Internet Camera?

**A:** The Internet Camera is a standalone system connecting directly to an Ethernet or Fast Ethernet network. It is different from the conventional PC camera, the Internet Camera is an all-in-one system with built-in CPU and web-based solutions providing a low cost solution that can transmit high quality video images for monitoring. The Internet Camera can be managed remotely, accessed and controlled from any PC/Notebook over the Intranet or Internet via a web browser.

**Q:** What is the maximum number of users that can be allowed to access the Internet Camera simultaneously?

**A:** Maximum number of users that can log onto the Internet Camera at the same time is 64. Please keep in mind the overall performance of the transmission speed will slow down when many users are logged on.

**Q:** What algorithm is used to compress the digital image?

**A:** The Internet Camera utilizes the JPEG image compression technology providing high quality images for users. JPEG is adopted since it is a standard for image compression and can be applied to various web browser and application software without the need to install extra software.

## **Internet Camera Installation**

**Q:** Can the Internet Camera be used out-doors?

**A:** The Internet Camera is not weatherproof. It needs to be equipped with a weatherproof case to be used outdoors and it is not recommended.

**Q:** What network cabling is required for the Internet Camera?

**A:** The Internet Camera uses Category 5 UTP cable allowing 10 Base-T and 100 Base-T networking.

**Q:** Can the Internet Camera be setup as a PC-cam on the computer?

**A:** No, the Internet Camera is an Internet Camera used only on Ethernet and Fast Ethernet network.

**Q:** Can the Internet Camera be connected on the network if it consists of only private IP addresses?

**A:** The Internet Camera can be connected to LAN with private IP addresses.

**Q:** Can the Internet Camera be installed and work if a firewall exists on the network?

**A:** If a firewall exists on the network, port 80 is open for ordinary data communication. However, since the Internet Camera



transmits image data, the default port 8481 is also required. Therefore, it is necessary to open port 8481 of the network for remote users to access the Internet Camera.

---

## **B PING Your IP Address**

---

The PING (Packet Internet Groper) command can determine whether a specific IP address is accessible by sending a packet to the specific address and waiting for a reply. It can also provide a very useful tool to confirm if the IP address conflicts with the Internet Camera over the network.

Follow the step-by-step procedure below to utilize the PING command. However, you must disconnect the Internet Camera from the network first.

Start a DOS window.

Type ping x.x.x.x, where x.x.x.x is the IP address of the Internet Camera.

The succeeding replies as illustrated below will provide useful explanation to the cause of the problem with the Internet Camera IP address.

---

## C Trouble Shooting

---

**Q:** I cannot access the Internet Camera from a web browser.

**A1:** The possible cause might be the IP Address for the Internet Camera is already being used by another device. To correct the possible problem, you need to first disconnect the Internet Camera from the network. Then run the PING utility (follow the instructions in Appendix B - PING Your IP Address).

**A2:** Another possible reason is the IP Address is located on a different subnet. To fix the problem, run the PING utility (follow the instructions in Appendix B - PING Your IP Address). If the utility returns “no response” or similar, the finding is probably correct, then you should proceed as follows:

In Windows 95/98/2000 and Windows NT, double check the IP Address of the Internet Camera is within the same subnet as your workstation.

Click “Start”, “Setting”, “Control Panel”, and the “Network” icon. Select TCP/IP from the “Network” dialog box and from the “TCP/IP Properties” dialog box click “Specify an IP address”. If the Internet Camera is situated on a different subnet than your workstation, you will not be able to set the IP address from this workstation. To verify make sure the first 3 sections of the IP address of the Internet Camera corresponds to the first 3 sections of the workstation. Therefore the IP address of the Internet Camera must be set from a workstation on the same subnet.

**A3:** Other possible problems might be due to the network cable. Try replacing your network cable. Test the network interface of

the product by connecting a local computer to the unit, utilizing a standard Crossover (hub to hub) Cable. If the problem is not solved the Internet Camera might be faulty.

**Q:** Why does the Power LED not light up constantly?

**A:** The power supply used might be at fault. Confirm that you are using the provided power supply DC 5V for the Internet Camera and verify that the power supply is well connected.

**Q:** Why does the Link LED not light up properly?

**A1:** There might be a problem with the network cable. To confirm that the cables are working, PING the address of a know device on the network. If the cabling is OK and your network is reachable, you should receive a reply similar to the following (...bytes = 32 time = 2 ms).

**A2:** The network device utilized by the Internet Camera is not functioning properly such as hubs or switches. Confirm the power for the devices are well connected and functioning.

Under infrastructure mode make sure the SSID on the PC/Notebook and the Internet Camera must match with the access point's SSID.

**Q:** Why does the Internet Camera work locally but not externally?

**A1:** Might be caused from the firewall protection. Need to check the Internet firewall with your system administrator.

**A2:** The default router setting might be a possible reason. Need to double check if the configuration of the default router settings is required.

**Q:** Why does a series of broad vertical white line appears through out the image?

**A:** A likely issue is that the CMOS sensor becomes overloaded when the light source is too bright such as direct exposure to sunlight or halogen light. You need to reposition the Internet Camera into a more shaded area immediately as this will damage the CMOS sensor.

**Q:** Noisy images occur how can I solve the problem?

**A:** The video images might be noisy if the Internet Camera is used in a very low light environment. To solve this issue you need more lighting.

**Q:** There is poor image quality, how can I improve the image?

**A1:** A probable cause might be the incorrect display properties configuration for your desktop. You need to open the Display Properties on your desktop and configure your display to show at least 65'000 colors for example at least 16-bit.

**NOTE:** *Applying only 16 or 256 colors on your computer will produce dithering artifacts in the image.*

**A2:** The configuration on the Internet Camera image display is incorrect. Through the Web Configuration Image section you need to adjust the image related parameter for improve images such as brightness, contrast, hue and light frequency. Please refer to the Web Configuration section for detail information.

**Q:** There are no images available through the web browser?

**A:** The ActiveX might be disabled. If you are viewing the images from Internet Explorer make sure ActiveX has been enabled in

the Internet Options menu. Alternatively, you can use the Java Applet for viewing the required images.

---

# D Time Zone Table

---

(GMT-12:00) Eniwetok, Kwajalein

(GMT-11:00) Midway Island, Samoa

(GMT-10:00) Hawaii

(GMT-09:00) Alaska

(GMT-08:00) Pacific Time (US & Canada); Tijuana

(GMT-07:00) Arizona

(GMT-07:00) Mountain Time (US & Canada)

(GMT-06:00) Central Time (US & Canada)

(GMT-06:00) Mexico City, Tegucigalpa

(GMT-06:00) Saskatchewan

(GMT-05:00) Bogota, Lima, Quito

(GMT-05:00) Eastern Time (US & Canada)

(GMT-05:00) Indiana (East)

(GMT-04:00) Atlantic Time (Canada)

(GMT-04:00) Caracas, La Paz

(GMT-04:00) Santiago

(GMT-03:30) Newfoundland

(GMT-03:00) Brasilia

(GMT-03:00) Buenos Aires, Georgetown

(GMT-02:00) Mid-Atlantic

(GMT-01:00) Azores, Cape Verde Is.

(GMT) Casablanca, Monrovia

(GMT) Greenwich Mean Time : Dublin, Edinburgh, Lisbon, London

(GMT+01:00) Amsterdam, Berlin, Bern, Rome, Stockholm, Vienna

(GMT+01:00) Belgrade, Bratislava, Budapest, Ljubljana, Prague

(GMT+01:00) Brussels, Copenhagen, Madrid, Paris, Vilnius

(GMT+01:00) Sarajevo, Skopje, Sofia, Warsaw, Zagreb

(GMT+02:00) Athens, Istanbul, Minsk

(GMT+02:00) Bucharest

(GMT+02:00) Cairo

(GMT+02:00) Harare, Pretoria

(GMT+02:00) Helsinki, Riga, Tallinn

(GMT+02:00) Jerusalem

(GMT+03:00) Baghdad, Kuwait, Riyadh

(GMT+03:00) Moscow, St. Petersburg, Volgograd

(GMT+03:00) Nairobi

(GMT+03:30) Tehran

(GMT+04:00) Abu Dhabi, Muscat

(GMT+04:00) Baku, Tbilisi

(GMT+04:30) Kabul

(GMT+05:00) Ekaterinburg

(GMT+05:00) Islamabad, Karachi, Tashkent

(GMT+05:30) Bombay, Calcutta, Madras, New Delhi

(GMT+06:00) Astana, Almaty, Dhaka

(GMT+06:00) Colombo

(GMT+07:00) Bangkok, Hanoi, Jakarta  
(GMT+08:00) Beijing, Chongqing, Hong Kong, Urumqi  
(GMT+08:00) Perth  
(GMT+08:00) Singapore  
(GMT+08:00) Taipei  
(GMT+09:00) Osaka, Sapporo, Tokyo  
(GMT+09:00) Seoul  
(GMT+09:00) Yakutsk  
(GMT+09:30) Adelaide  
(GMT+09:30) Darwin  
(GMT+10:00) Brisbane  
(GMT+10:00) Canberra, Melbourne, Sydney  
(GMT+10:00) Guam, Port Moresby  
(GMT+10:00) Hobart  
(GMT+08:00) Singapore  
(GMT+08:00) Taipei  
(GMT+09:00) Osaka, Sapporo, Tokyo  
(GMT+09:00) Seoul  
(GMT+09:00) Yakutsk  
(GMT+09:30) Adelaide  
(GMT+09:30) Darwin  
(GMT+10:00) Brisbane  
(GMT+10:00) Canberra, Melbourne, Sydney  
(GMT+10:00) Guam, Port Moresby  
(GMT+10:00) Hobart  
(GMT+10:00) Vladivostok  
(GMT+11:00) Magadan, Solomon Is., New Caledonia  
(GMT+12:00) Auckland, Wellington  
(GMT+12:00) Fiji, Kamchatka, Marshall Is.



---

# E Xplug Control Installation

---

## Installation To Web Server

### **Important Information**

It is highly recommended to install the Xplug Control application to the Web Server for IE 5.0. It must be installed to a Public Domain with Fixed IP address.

#### **1. Installation:**

Copy the “xplug.ocx” file to any WEB Server table.

#### **2. Setting (Configuration):**

From the Web Configuration menu select “System” and under the “Loading ActiveX From” input web server location

(<http://www.web server location.com/>).

Once the settings are completed, the user now is able to access the Internet Camera from the web browser by selecting the image view – ActiveX mode.

# Software Installation

Insert the CD-ROM into the CD-ROM drive to initiate the auto-run program. Once completed, a menu screen will appear as below:



To install Xplug Control, click the “**Xplug Control**” button to activate the installation procedure for the plug-in program.

Once executed, a prompt will appear requesting the input of the desired language selection. Make the desired selection and click “**OK**” to continue.



The Welcome screen will appear. Click the “**Next**” button to proceed with the installation.

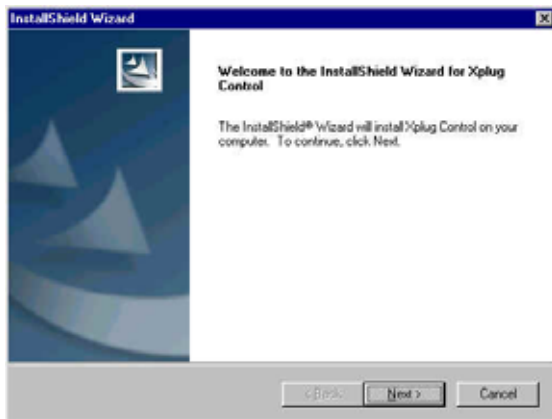

The License Agreement prompt will appear as below. Read the details carefully and click the “**Yes**” button to continue with the installation procedure.

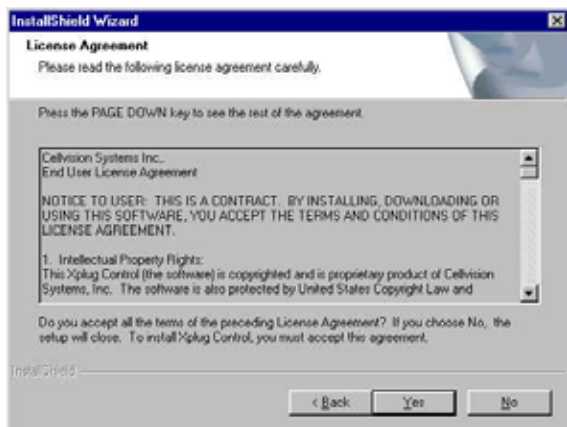

Click the **“Finish”** button to complete Setup of the Xplug Control Utility program for the Internet Camera.

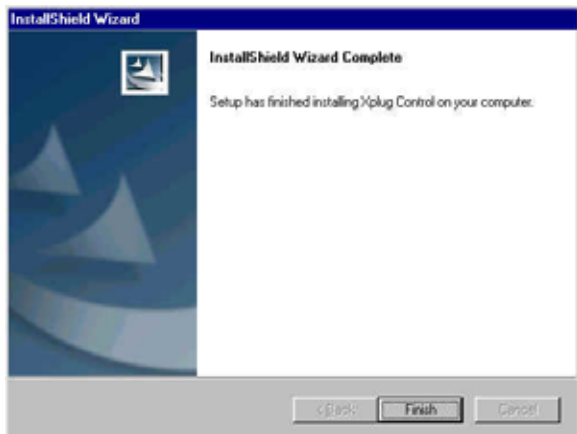

---

## F Adjust Internet Camera Focus

---

To adjust the focus of the lens, you need to turn the lens slowly in either clockwise or anti-clockwise direction until the desired image appears. DO NOT over turn the lens in either of the directions, as it will be out of focus.

**NOTE:** You can further adjust the Internet Camera's image quality through System Administration – Image of Web Configuration. Please refer to Web Configuration section for further details.

### **Warning**

Direct exposure to sunlight may cause permanent damage to the CMOS sensor. Therefore do not expose the Internet Camera's lens directly to sunlight. When operation is required in glaring light environment, it is recommended to use an iris lens.

The Internet Camera is designed for indoor usage and if your application requires prolong exposure to sunlight, a sun visor is recommended to protect the Internet Camera.

---

# G Specification

---

## Video specification

Resolution:	640 x 480 pixel
Sensor:	Color CMOS sensor
Lens:	f: 6.0 mm, F: 1.8
Gain control:	Automatic
Exposure:	Automatic
White Balance:	Automatic

## Image (Video Setting)

Image compression:	JPEG
Frame rate:	30fps @ QCIF, 25fps @ CIF, 10fps @ VGA
Compression Rate selection:	5 levels: Very low/Low/ Middle/High/Very high
Frame rate setting:	1, 5, 7, 15, 20, Auto (depends on the video format)
Video resolution:	160x120, 320x240, 640x480
Digital Zoom:	Supported
Horizontal/ Vertical mirror:	Supported

## Hardware Interface

LAN Connector:	One RJ-45 port, 10/100M auto-sensed, Auto-MDIX
Communication protocol:	HTTP, FTP, TCP/IP, UDP, ARP, ICMP, BOOTP, DHCP, PPPoE, SMTP, DDNS, UPnP
CPU:	RDC R2880
RAM:	8MB
Flash ROM:	2MB

OS:	RTOS
Power Supply:	DC 5V, switching type
Power consumption:	3.5 Watt (700mA x 5V)
LED Indicator:	Power LED (Blue) Activity LED (Orange)

## **Software**

Browser:	Internet Explorer 5.0 or above; Netscape 6.0 or above
Application Software:	IPView Pro
OS supported:	Microsoft Windows 98SE/ME/ 2000/XP, Windows NT4.0

## **Operating environment**

Operating temperature:	5 <sup>o</sup> C ~ 40 <sup>o</sup> C
Storage temperature:	-25 <sup>o</sup> C ~ 50 <sup>o</sup> C
Humidity:	5% ~ 95%, non-condensing

## **EMI**

FCC, CE, VCCI Class B

---

# H Glossary of Terms

---

## NUMBERS

**10BASE-T** 10BASE-T is Ethernet over UTP Category III,IV, or V unshielded twisted-pair media.

**100BASE-TX** The two-pair twisted-media implementation of 100BASE-T is called *100BASE-TX*.

## A

**Applet** Applets are small Java programs that can be embedded in an HTML page. The rule at the moment is that an applet can only make an Internet connection to the computer from that the applet was sent.

**ASCII** American Standard Code For Information Interchange, it is the standard method for encoding characters as 8-bit sequences of binary numbers, allowing a maximum of 256 characters.

**ARP** Address Resolution Protocol. ARP is a protocol that resides at the TCP/IP Internet layer that delivers data on the same network by translating an IP address to a physical address.

**AVI** Audio Video Interleave, it is a Windows platform audio and video file type, a common format for small movies and videos.



## B

### **BOOTP**

Bootstrap Protocol is an Internet protocol that can automatically configure a network device in a diskless workstation to give its own IP address.

## C

**Communication** Communication has four components: sender, receiver, message, and medium. In networks, devices and application tasks and processes communicate messages to each other over media. They represent the sender and receivers. The data they send is the message. The cabling or transmission method they use is the medium.

### **Connection**

In networking, two devices establish a connection to communicate with each other.

## D

### **DHCP**

Dynamic Host Configuration Protocol was developed by Microsoft a protocol for assigning dynamic IP addresses to devices on a network. With dynamic addressing, a device can have a different IP address every time it connects to the network. In some systems, the device's IP address can even change while it is still connected. DHCP also supports a mix of static and dynamic IP addresses. This simplifies the task for network administrators because the software keeps track of IP addresses rather than requiring an administrator to manage the task. This means a new computer can be added to a network without the hassle

of manually assigning it a unique IP address. DHCP allows the specification for the service provided by a router, gateway, or other network device that automatically assigns an IP address to any device that requests one

## **DNS**

Domain Name System is an Internet service that translates domain names into IP addresses. Since domain names are alphabetic, they're easier to remember. The Internet however, is really based on IP addresses every time you use a domain name the DNS will translate the name into the corresponding IP address. For example, the domain name *www.network\_camera.com* might translate to *192.167.222.8*.

## **E**

### **Enterprise network**

An enterprise network consists of collections of networks connected to each other over a geographically dispersed area. The enterprise network serves the needs of a widely distributed company and operates the company's mission-critical applications.

### **Ethernet**

The most popular LAN communication technology. There are a variety of types of Ethernet, including 10 Mbps (traditional Ethernet), 100 Mbps (Fast Ethernet), and 1,000 Mbps (Gigabit Ethernet). Most Ethernet networks use Category 5 cabling to carry information, in the form of electrical signals, between devices. Ethernet is an implementation of CSMA/CD that operates in a bus or star topology.

## **F**

**Fast Ethernet** Fast Ethernet, also called 100BASE-T, operates at 10 or 100Mbps per second over UTP, STP, or fiber-optic media.

## **Firewall**

Firewall is considered the first line of defense in protecting private information. For better security, data can be encrypted. A system designed to prevent unauthorized access to or from a private network. Firewalls are frequently used to prevent unauthorized Internet users from accessing private networks connected to the Internet, especially Intranets all messages entering or leaving the intranet pass through the firewall, which examines each message and blocks those that do not meet the specified security criteria.

## **G**

### **Gateway**

A gateway links computers that use different data formats together.

### **Group**

Groups consist of several user machines that have similar characteristics such as being in the same department.

## **H**

### **HEX**

Short for hexadecimal refers to the base-16 number system, which consists of 16 unique symbols: the numbers 0 to 9 and the letters A to F. For example, the decimal number 15 is represented as F in the hexadecimal numbering system. The hexadecimal system is useful because it can represent every byte (8 bits) as two consecutive hexadecimal digits. It is easier

for humans to read hexadecimal numbers than binary numbers.

## I

**IEEE** Institute of Electrical and Electronic Engineers.

**Intranet** This is a private network, inside an organization or company, that uses the same software you will find on the public Internet. The only difference is that an Intranet is used for internal usage only.

**Internet** The Internet is a globally linked system of computers that are logically connected based on the Internet Protocol (IP). The Internet provides different ways to access private and public information worldwide.

**Internet address** To participate in Internet communications and on Internet Protocol-based networks, a node must have an Internet address that identifies it to the other nodes. All Internet addresses are IP addresses

**IP** Internet Protocol is the standard that describes the layout of the basic unit of information on the Internet (the *packet*) and also details the numerical addressing format used to route the information. Your Internet service provider controls the IP address of any device it connects to the Internet. The IP addresses in your network must conform to IP addressing rules. In smaller LANs, most people will allow the DHCP function of a router or gateway to assign the IP addresses on internal networks.

**IP address** IP address is a 32-binary digit number that identifies each sender or receiver of information that is sent in

packets across the Internet. For example 80.80.80.69 is an IP address, it is the closest thing the Internet has to telephone numbers. When you “call” that number, using any connection methods, you get connected to the computer that “owns” that IP address.

## **ISP**

Internet Service Provider, is a company that maintains a network that is linked to the Internet by way of a dedicated communication line. An ISP offers the use of its dedicated communication lines to companies or individuals who can't afford the high monthly cost for a direct connection.

## **J**

### **JAVA**

Java is a programming language that is specially designed for writing programs that can be safely downloaded to your computer through the Internet without the fear of viruses. It is an object-oriented multi-thread programming best for creating applets and applications for the Internet, Intranet and other complex, distributed network.

## **L**

### **LAN**

Local Area Network a computer network that spans a relatively small area sharing common resources. Most LANs are confined to a single building or group of buildings.

## **N**

**NAT** Network Address Translator generally applied by a router, that makes many different IP addresses on an internal network appear to the Internet as a single address. For routing messages properly within your network, each device requires a unique IP address. But the addresses may not be valid outside your network. NAT solves the problem. When devices within your network request information from the Internet, the requests are forwarded to the Internet under the router's IP address. NAT distributes the responses to the proper IP addresses within your network.

**Network** A network consists of a collection of two or more devices, people, or components that communicate with each other over physical or virtual media. The most common types of network are:  
**LAN** – (local area network): Computers are in close distance to one another. They are usually in the same office space, room, or building.  
**WAN** – (wide area network): The computers are in different geographic locations and are connected by telephone lines or radio waves.

**NWay Protocol** A network protocol that can automatically negotiate the highest possible transmission speed between two devices.

## **P**

**PING** Packet Internet Groper, a utility used to determine whether a specific IP address is accessible. It functions by sending a packet to the specified address and waits for a reply. It is primarily used to troubleshoot Internet

connections.

### **PPPoE**

Point-to-Point Protocol over Ethernet. PPPoE is a specification for connecting the users on an Ethernet to the Internet through a common broadband medium, such as DSL or cable modem. All the users over the Ethernet share a common connection.

### **Protocol**

Communication on the network is governed by sets of rules called protocols. Protocols provide the guidelines devices use to communicate with each other, and thus they have different functions. Some protocols are responsible for formatting and presenting and presenting data that will be transferred from file server memory to the file server's network adapter Others are responsible for filtering information between networks and forwarding data to its destination. Still other protocols dictate how data is transferred across the medium, and how servers respond to workstation requests and vice versa. Common network protocols responsible for the presentation and formatting of data for a network operating system are the Internetwork Packet Exchange (IPX) protocol or the Internet Protocol (IP). Protocols that dictate the format of data for transferers the medium include token-passing and Carrier Sense Multiple Access with Collision Detection (CSMA/CD), implemented as token-ring, ARCNET, FDDI, or Ethernet. The Router Information Protocol (RIP), a part of the Transmission Control Protocol/Internet Protocol (TCP/IP) suite, forwards packets from one network to another using the same network protocol.

## **R**

**RARP** Reverse Address Resolution Protocol, a TCP/IP protocol that allows a physical address, such as an Ethernet address, to be translated into an IP address.

**RJ-45** RJ-45 connector is used for Ethernet cable connections.

**Router** A router is the network software or hardware entity charged with routing packets between networks.

## **S**

**Server** It is a simple computer that provides resources, such as files or other information.

**SMTP** The Simple Mail Transfer Protocol is used for Internet mail.

**SNMP** Simple Network Management Protocol. SNMP was designed to provide a common foundation for managing network devices.

**Station** In LANs, a station consists of a device that can communicate data on the network. In FDDI, a station includes both physical nodes and addressable logical devices. Workstations, single-attach stations, dual-attach stations, and concentrators are FDDI stations.

**Subnet mask** In TCP/IP, the bits used to create the subnet are called the subnet mask.

## **T**



**(TCP/IP)** Transmission Control Protocol/Internet Protocol is a widely used transport protocol that connects diverse computers of various transmission methods. It was developed by the Department of Defense to connect different computer types and led to the development of the Internet.

**Transceiver** A transceiver joins two network segments together. Transceivers can also be used to join a segment that uses one medium to a segment that uses a different medium. On a 10BASE-5 network, the transceiver connects the network adapter or other network device to the medium. Transceivers also can be used on 10BASE-2 or 10BASE-T networks to attach devices with AUI ports.

## U

**UDP** The User Datagram Protocol is a connectionless protocol that resides above IP in the TCP/IP suite

**ULP** The upper-layer protocol refers to Application Layer protocols such as FTP, SNMP, and SMTP.

**User Name** The USERNAME is the unique name assigned to each person who has access to the LAN.

**Utility** It is a program that performs a specific task.

**UTP** Unshielded twisted-pair. UTP is a form of cable used by all access methods. It consists of several pairs of wires enclosed in an unshielded sheath.

## W

<b>WAN</b>	Wide-Area Network. A wide-area network consists of groups of interconnected computers that are separated by a wide distance and communicate with each other via common carrier telecommunication techniques.
<b>Windows</b>	Windows is a graphical user interface for workstations that use DOS.
<b>Workgroup</b>	A workgroup is a group of users who are physically located together and connected to the same LAN, or a group of users who are scattered throughout an organization but are logically connected by work and are connected to the same network group.
<b>Workstations</b>	Workstation refers to the intelligent computer on the user's desktop. This computer may be an Intel-based PC, a Macintosh, or a UNIX-based workstation. The workstation is any intelligent device a user works from.