



**2Mega-Pixel
15M IR Vandal Proof Dome IP Camera**

ICA-HM136

User's Manual

Version: 1.00

Copyright

Copyright © 2011 by PLANET Technology Corp. All rights reserved. No part of this publication may be reproduced, transmitted, transcribed, stored in a retrieval system, or translated into any language or computer language, in any form or by any means, electronic, mechanical, magnetic, optical, chemical, manual or otherwise, without the prior written permission of PLANET.

PLANET makes no representations or warranties, either expressed or implied, with respect to the contents hereof and specifically disclaims any warranties, merchantability or fitness for any particular purpose. Any software described in this manual is sold or licensed "as is". Should the programs prove defective following their purchase, the buyer (and not PLANET, its distributor, or its dealer) assumes the entire cost of all necessary servicing, repair, and any incidental or consequential damages resulting from any defect in the software. Further, PLANET reserves the right to revise this publication and to make changes from time to time in the contents hereof without obligation to notify any person of such revision or changes.

All brand and product names mentioned in this manual are trademarks and/or registered trademarks of their respective holders.

Federal Communication Commission Interference Statement

This equipment has been tested and found to comply with the limits for a Class B digital device, pursuant to Part 15 of FCC Rules. These limits are designed to provide reasonable protection against harmful interference in a residential installation. This equipment generates, uses, and can radiate radio frequency energy and, if not installed and used in accordance with the instructions, may cause harmful interference to radio communications. However, there is no guarantee that interference will not occur in a particular installation. If this equipment does cause harmful interference to radio or television reception, which can be determined by turning the equipment off and on, the user is encouraged to try to correct the interference by one or more of the following measures:

1. Reorient or relocate the receiving antenna.
2. Increase the separation between the equipment and receiver.
3. Connect the equipment into an outlet on a circuit different from that to which the receiver is connected.
4. Consult the dealer or an experienced radio technician for help.

FCC Caution

To assure continued compliance. (example-use only shielded interface cables when connecting to computer or peripheral devices). Any changes or modifications not expressly approved by the party responsible for compliance could void the user's authority to operate the equipment.

This device complies with Part 15 of the FCC Rules. Operation is subject to the Following two conditions: (1) This device may not cause harmful interference, and (2) this Device must accept any interference received, including interference that may cause undesired operation.

Federal Communication Commission (FCC) Radiation Exposure Statement

This equipment complies with FCC radiation exposure set forth for an uncontrolled environment. In order to avoid the possibility of exceeding the FCC radio frequency exposure limits, human proximity to the antenna shall not be less than 20 cm (8 inches) during normal operation.

Safety

This equipment is designed with the utmost care for the safety of those who install and use it. However, special attention must be paid to the dangers of electric shock and static electricity when working with electrical equipment. All guidelines of this and of the computer manufacture must therefore be allowed at all times to ensure the safe use of the equipment.

CE Mark Warning

This is a Class B product. In a domestic environment, this product may cause radio interference, in which case the user may be required to take adequate measures.

WEEE Regulation



To avoid the potential effects on the environment and human health as a result of the presence of hazardous substances in electrical and electronic equipment, end users of electrical and electronic equipment should understand the meaning of the crossed-out wheeled bin symbol. Do not dispose of WEEE as unsorted municipal waste and have to collect such WEEE separately.

Revision

User's Manual for PLANET H.264 2Mega-Pixel 15M IR Vandal Proof Dome IP Camera
Model: ICA-HM136
Rev: 1.00 (December. 2010)
Part No. EM-ICAHM136

Table of Content

1.	Introduction.....	6
1.1	Overview.....	6
1.2	Features.....	6
1.3	Package Contents.....	7
2.	Basic Setup.....	8
2.1	System Requirements.....	8
2.2	Physical Description.....	9
2.2.1	Identification of ICA-HM136 cable.....	9
2.2.2	ICA-HM136 I/O Control Instruction.....	10
2.3	Hardware Installation.....	12
2.3.1	Physical Installation.....	12
2.4	Initial Utility Installation.....	15
2.5	Initial Utility Installation.....	15
2.5.1	Search and Configure Network by PLANET IP Installer.....	15
	Search and Configure Network.....	15
2.6	Setup ActiveX to use the Internet Camera.....	19
2.6.1	Internet Explorer 6 for Windows XP.....	19
2.6.2	Internet Explorer 7 for Windows XP.....	20
2.6.3	Internet Explorer 7 for Windows Vista.....	21
3.	Web-based Management.....	22
3.1	Introduction.....	22
3.2	Connecting to Internet Camera.....	22
4.	Live View.....	24
5.	Configuration.....	26
5.1	System.....	27
5.1.1	System Information.....	27
5.1.2	User Management.....	29
5.1.3	System Update.....	30
5.2	Network.....	31
5.2.1	IP Setting.....	31
5.2.2	Using UPnP of Windows XP or Vista.....	32
5.2.3	PPPoE.....	39
5.2.4	DDNS.....	39
5.2.5	Mail & FTP.....	42
5.3	A/V Setting.....	43
5.3.1	Image Setting.....	43
5.3.2	Video Setting.....	43
5.3.3	Audio.....	46
5.4	Event List.....	48
5.4.1	Event Setting.....	48
5.4.2	Schedule.....	49
5.4.3	I/O Setting.....	50
5.4.4	Log List.....	52
5.4.5	SD Card.....	52
	Appendix A: Factory Default.....	54

Appendix B: PING IP Address.....	55
Appendix C: 3GPP Access	56
Appendix D: Bandwidth and Video Size Estimation	57
Appendix E: DDNS Application	58
Appendix F: Configure Port Forwarding Manually	63
Appendix G: SD Card Recommended.....	66
Appendix H: Troubleshooting & Frequently Asked Questions	67
Appendix I: Product Specification	71

1. Introduction

Thank you for purchasing the H.264 2Mega-Pixel 15 meter outdoor infrared vandal proof Internet Camera ICA-HM136. Simultaneously providing H.264, MPEG-4 and M-JPEG video streaming, provides small video size and save you lots of bandwidth. The ICA-HM136 through high performance 2Mega-Pixel CMOS sensor, it delivers high quality image at maximum 1600x1200(UXGA) resolutions for capturing color images. Also equipped with 2.7mm to 9mm Vari-focal auto iris lens, it allows easy installation and camera angle adjustment for different installed sites.

Built-in 18 IR LED around the lens of the ICA-HM136 and with the built-in IR-cut filter, the ICA-HM136 can provide good video quality in both day and night. And it's equipped with network and analog video output interfaces for flexible viewing and recording implementations.

The ICA-HM136 IP Compliant with IEEE 802.3af PoE interface for quick and easy installation in the ceiling without concerning the outlet / socket locations and also eliminates the need of power cables and installation costs. And the ICA-HM136 supports 2-Way audio that can let administrator speaks to anyone directly to make audio communication between local and remote ICA-HM136 installed sites by using the external microphone and adding an external speaker.

PLANET ICA-HM136 designed with vandal-proof and IP66 weather-proof case that can shield 400 pounds of impact. The vandal-proof design with die-cast aluminum body prevents the intentional destruction. Water-resistant construction with weather-proof solid housing maintains the reliable operation in any environment. It is the perfect choice for outdoor surveillance system by providing IP-66 certified water-proof protection.

The ICA-HM136 can be managed by PLANET Cam Viewer Three, the professional IP-Surveillance management software for multi-camera video surveillance application, that provides monitoring, recording and event management functions. The Cam Viewer Three enables you to setup a comprehensive and effective surveillance system quickly and easily, it provides an enhanced, professional, and secured environment to protect your property and life.

1.1 Overview

This user's guide explains how to operate this camera from a computer. User should read this manual completely and carefully before you operate the device

1.2 Features

- High resolution pictures for day and night with high quality of 2 Mega-Pixel CMOS image sensor
- Built-in IR LED and visible distance up to 15 meters
- Support 3GPP and JAVA for iPhone and Windows mobile for remote view
- Supports H.264, MPEG-4 and M-JPEG video compression
- Easy configuration and management via Windows-Based utility or web browser
- DDNS, PPPoE and FTP uploading offers more alternatives in surveillance network
- Motion Detection feature can monitor any suspicious movement in a specific area
- 2-Way audio supported with external speaker and microphone
- IR-Cut filter brings better video quality in the daytime and nighttime

- IP-66 protection for outdoor application
- Compliant with IEEE 802.3af PoE interface

1.3 Package Contents

User can find the following items in the package:

Camera unit x 1

Power Adapter x 1

Accessories Kit x 1

User's Manual CD x 1

Quick Installation Guide x 1

- NOTE:**
1. If any of the above items are missing, please contact your dealer immediately.
 2. Using the power supply that is not the one included in Internet camera packet will cause damage and void the warranty for this product.

2. Basic Setup

This chapter provides details of installing and configuring the internet camera

2.1 System Requirements

Network Interface	10/100MBase-TX Ethernet
Monitoring System	Recommended for Internet Explorer 6.0 or later
System Hardware (Suggested)	<ul style="list-style-type: none">· CPU: Intel Dual Core 1.66G· Memory Size : 1024 MB (1024 MB or above Recommended)· VGA card resolution : 1024 x 768 or above· VGA card memory : 128 MB or above
System Hardware (Minimum)	<ul style="list-style-type: none">· CPU: Intel C-2.8G· Memory Size : 512 MB· VGA card resolution : 1024 x 768· VGA card memory : 64 MB

NOTE:

The listed information is minimum system requirements only. Actual requirement will vary depending on the nature of your environment.

2.2 Physical Description

2.2.1 Identification of ICA-HM136 cable

1.**RJ-45 LAN socket:** Connect to PC or Hub/Switch.

For connect to 10Base-T Ethernet or 100Base-TX Fast Ethernet cabling. This Ethernet port built N-Way protocol can detect or negotiate the transmission speed of the network automatically. Please use CAT-5 cable to connect the Network Camera to a 100Mbps Fast Ethernet network switch or hub.

2.**Power Jack:** The input power is DC 12V.

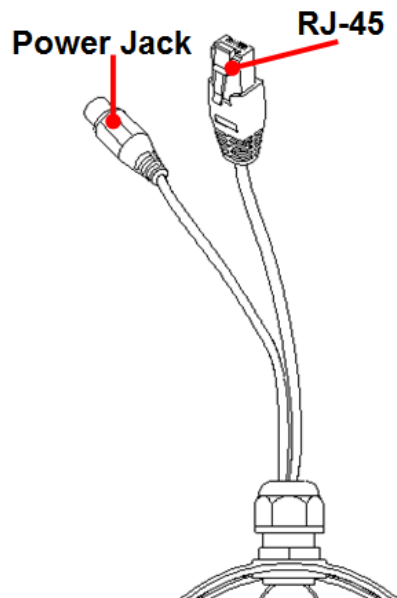

NOTE: ONLY use package power adapter supplied with the internet. Otherwise, the product may be damaged.

2.2.2 ICA-HM136 I/O Control Instruction

I/O terminal connector – used in application, for e.g., motion detection, event triggering,

(1)Digital Input: (GND+Alarm)

An alarm input for connecting devices that can toggle between an open and closed circuit, for example: PIRs, door/window contacts, glass break detectors, etc. When a signal is received the state changes and the input becomes active.

(2)Relay output: (COM +N.O.) / (COM+N.C.)

An output to Relay switch, for example: LEDs, Sirens, etc.

1.Digital Input:

Alarm Input:

1. GND (Ground) : Initial state is LOW
2. Alarm : Max. 50mA, DC 3.3V

2.Relay Output:

1. N.C. (Normally Close): Max. 1A, 24VDC or 0.2A, 125~240VAC
2. COM: (Common)
3. N.O. (Normally Open): Max. 1A, 24VDC or 0.2A, 125~240VAC

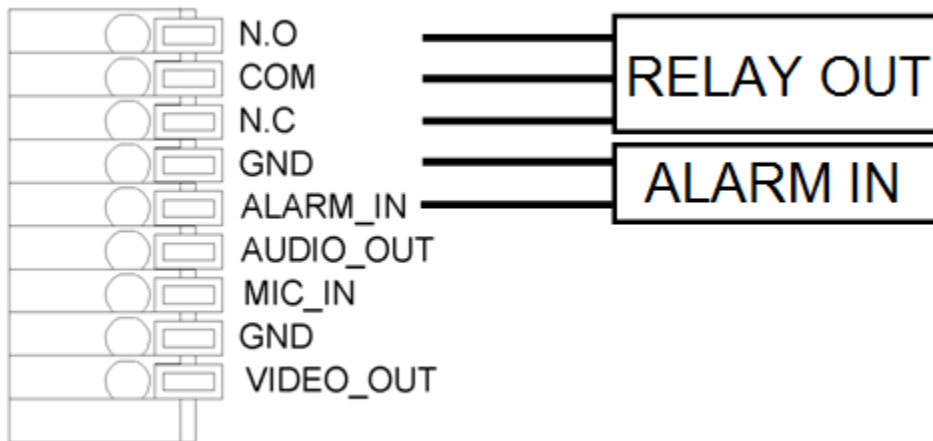

3.Relay Connection:

(1)Digital Input connection

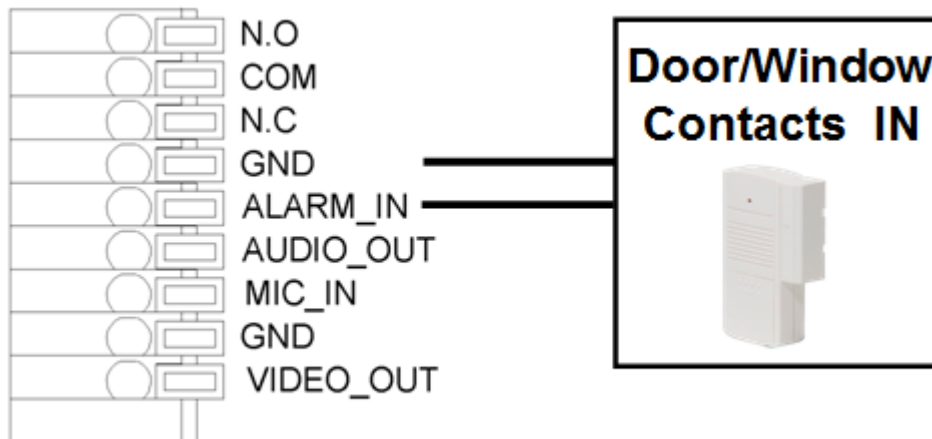

(2) Relay Output Connection

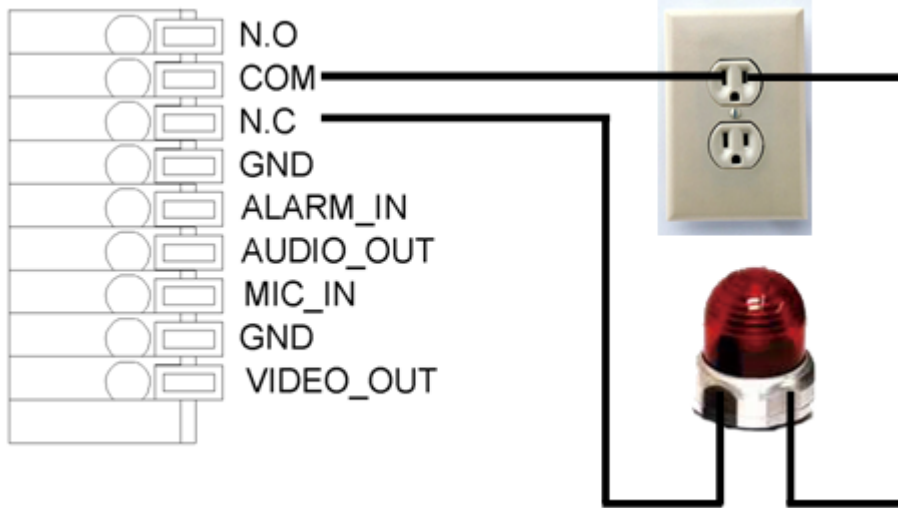

Or

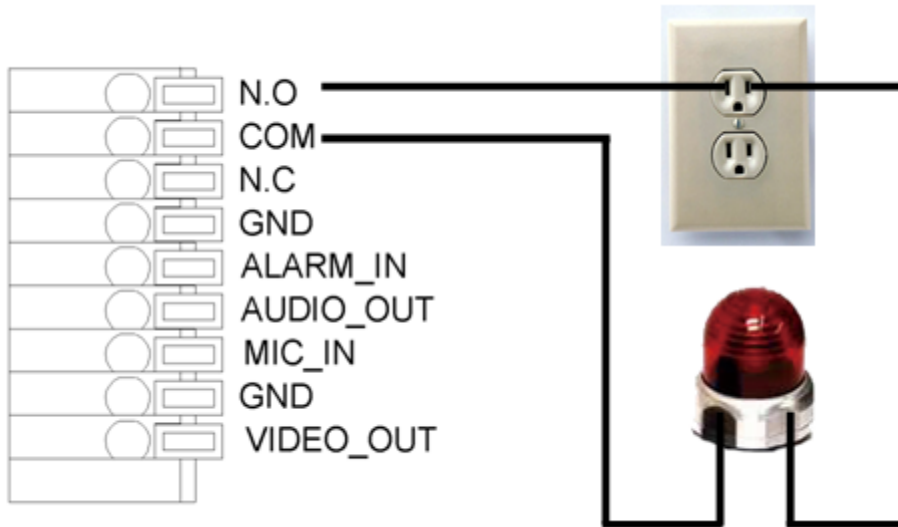

4.MIC_IN:

Connect a microphone to the network camera.

5.AUDIO_IN

Connect a loud speaker to the network camera. This is for voice alerting and two-way audio.

2.3 Hardware Installation

2.3.1 Physical Installation

1. Fix Internet camera to desired location with mount fixture
2. Connect an Ethernet cable

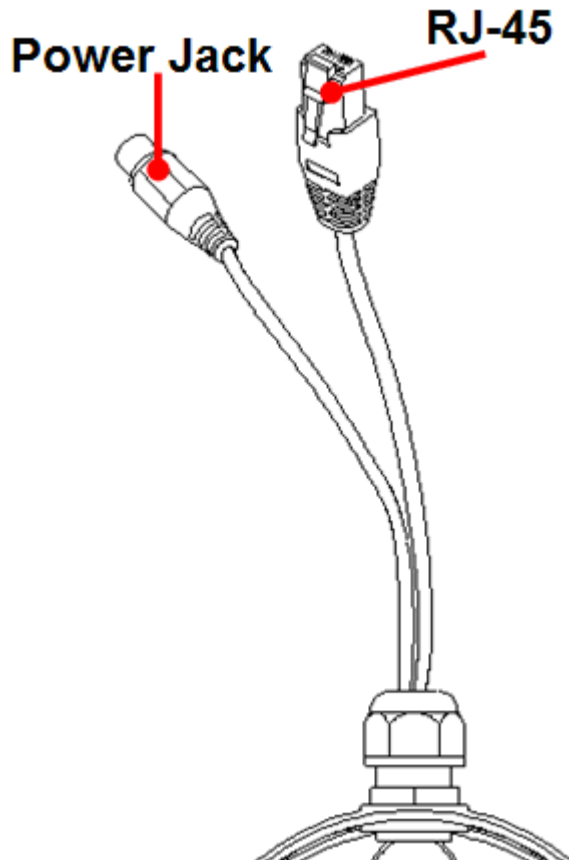

Connect the LAN cable on the camera to the network device (hub or switch).

NOTE: If there has an IEEE802.3af PoE switch in your network, you can connect the camera LAN cable to this PoE switch to obtain power. The power adapter is unnecessary when internet camera is connected to a PoE switch.

3. Attach the power supply

Plug in power adapter and connect to power source. After power on, the camera will start to operate.

- NOTE:**
1. Only use the power adapter supplied with internet camera. Otherwise, the product may be damaged.
 2. The power adapter is unnecessary when internet camera is connected to a PoE switch. Otherwise, the product may be damaged when internet camera is connected to a PoE switch and power adapter simultaneously.

4. Attach BNC connector

Connect the video BNC connector to a monitor set if necessary check camera viewing angle and focus.

5. 3-Axis Gimbal Adjustments

Once the users open the case, the gimbal adjustment offers the convenience method to install on the wall. The pan, tilt, and rotation are provided in this model. The users can adjust the gimbal with Pan 175 degree, tilt 75 degree, and rotation 180 degree respectively.

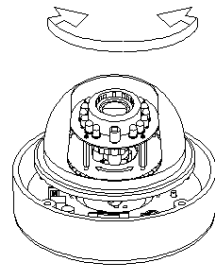

① Pan: 175°

② Tilt: 75°

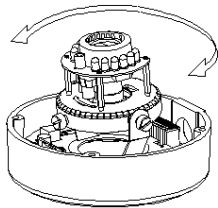

③ Rotation: 180°

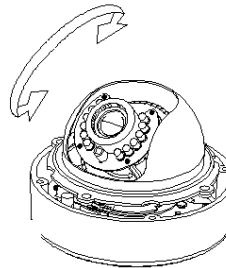

6. PoE (Power Over Ethernet)

PoE (Power Over Ethernet)(Optional) 802.3af, 15.4W PoE Switch is recommended Power over Ethernet (PoE) is a technology that integrates power into a standard LAN infrastructure. It enables power to be provided to the network device, such as an IP phone or a network camera, using the same cable as that used for network connection. It eliminates the need for power outlets at the camera locations and enables easier application of uninterruptible power supplies (UPS) to ensure 24 hours a day, 7 days a week operation.

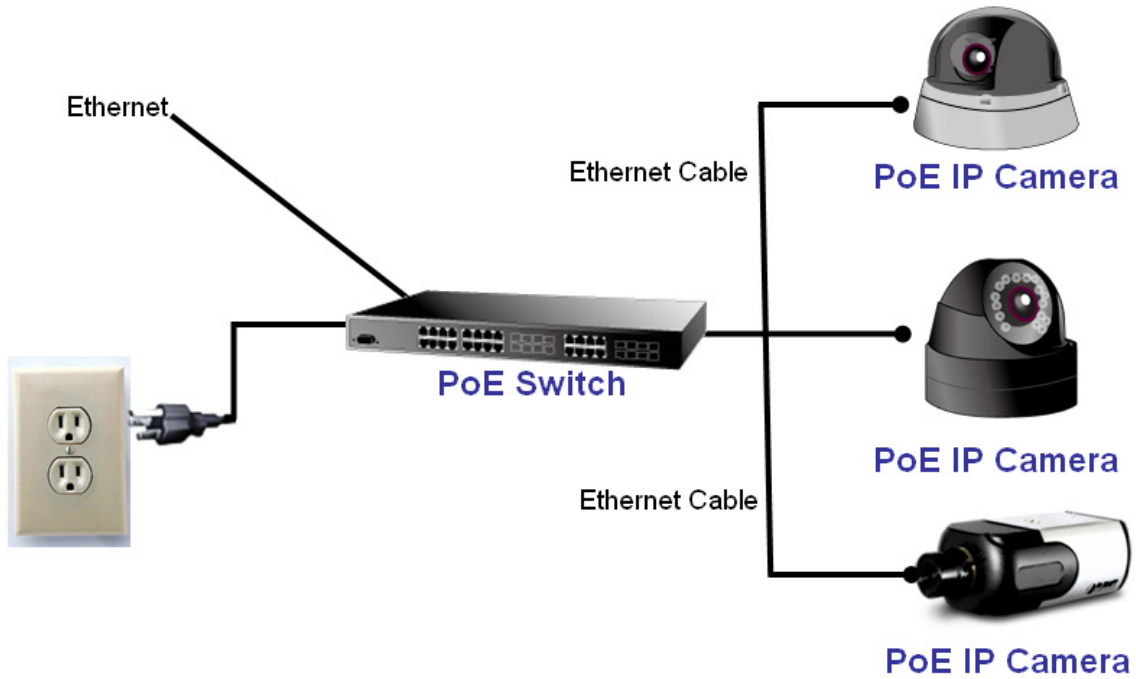

2.4 Initial Utility Installation

This chapter shows how to quick set up your H.264 camera. The camera is with the default settings. However to help you find the networked camera quickly the windows utility PLANET IP Installer can search the cameras in the network that shall help you to configure some basic setting before you started advanced management and monitoring.

1. Insert the bundled CD into the CD-ROM drive to launch the auto-run program. Once completed, a welcome menu screen will appear.
2. Click the “PLANET IPInstaller” hyperlink; you will see the dialog box as below.

NOTE: If the welcome screen does not appear, click “Start” at the taskbar. Then, select “Run” and type “D:\Utility\PLANETIPinstaller\PLANETIPinstaller.exe”, assume CD is your CD-ROM drive.

2.5 Initial Utility Installation

When you installed the camera on a LAN environment, you may execute PLANET IP Installer to discover camera’s IP address and set up related parameters in the camera.

2.5.1 Search and Configure Network by PLANET IP Installer

When you installed the Camera on a LAN environment, you have two easy ways to search your Cameras by PLANET IP Installer or UPnP discovery. Here is the way to execute PLANET IP Installer to discover Camera’s IP address and set up related parameter in a Camera.

Search and Configure Network

1. OS: Windows XP SP2 or above. If the following “Windows Security Alert” popup, please click “Unblock”.



2. The GUI of IP Installer is as follows (Default IP: 192.168.0.20).

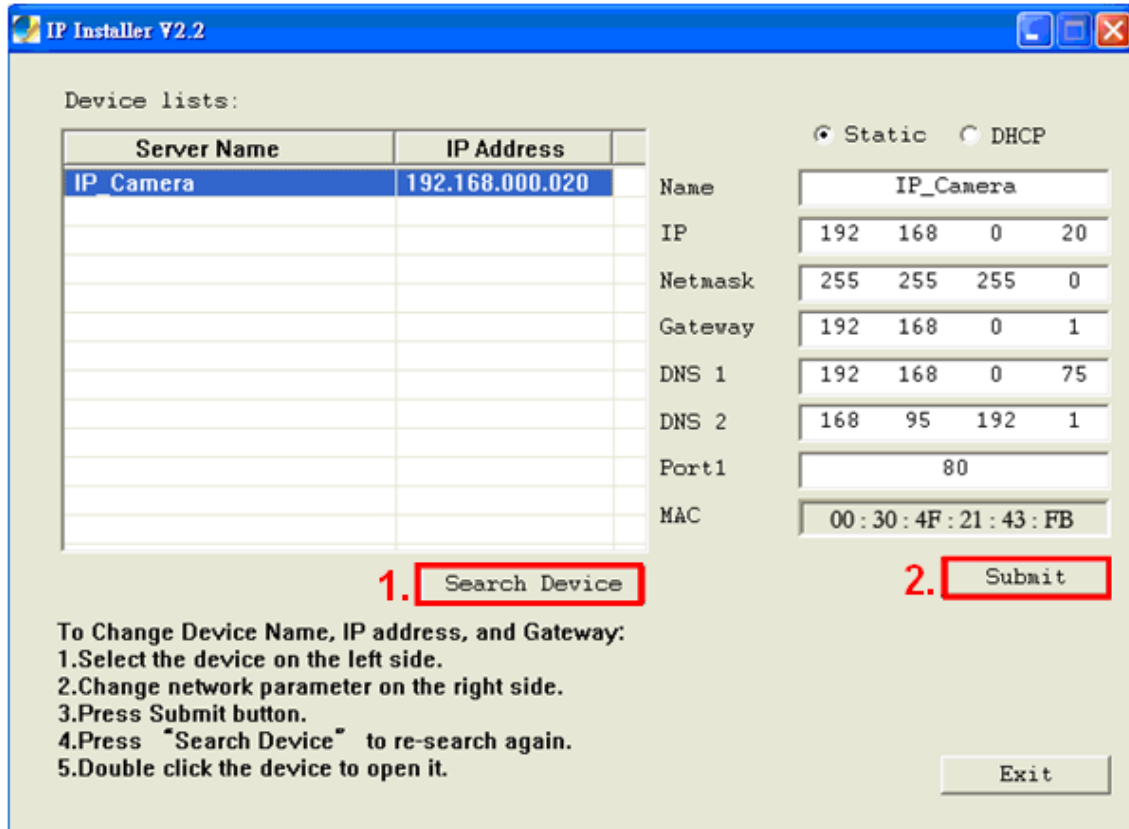

(1) IP Installer will search all IP Cameras connected on LAN. The user can click "**Search Device**" to search again.

(2) Click one of IP Cameras listed on the left side of IP Installer, then the network configuration of that IP Camera will be listed on the right side. If parameters changed, click on "**Submit**". Then, the network configuration will be changed. Just click "**OK**" to reboot

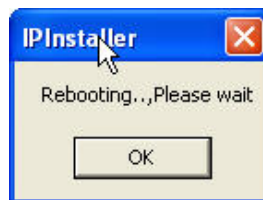

(3) Please make sure the subnet of PC IP address and IP CAM IP address are the same.
IP CAM IP address: 192.168.0.20
PC IP address: 192.168.0.20

(4) Different Subnets:
IP CAM IP address: 192.168.0.20
PC IP address: 192.168.1.100

(5) To Change PC IP address:
Control Panel → Network Connections → Local Area Connection Properties → Internet Protocol (TCP/IP) → Properties
Please make sure your IP Camera and PC have the same Subnet. If not, please change IP Camera IP subnet or PC IP subnet accordingly.

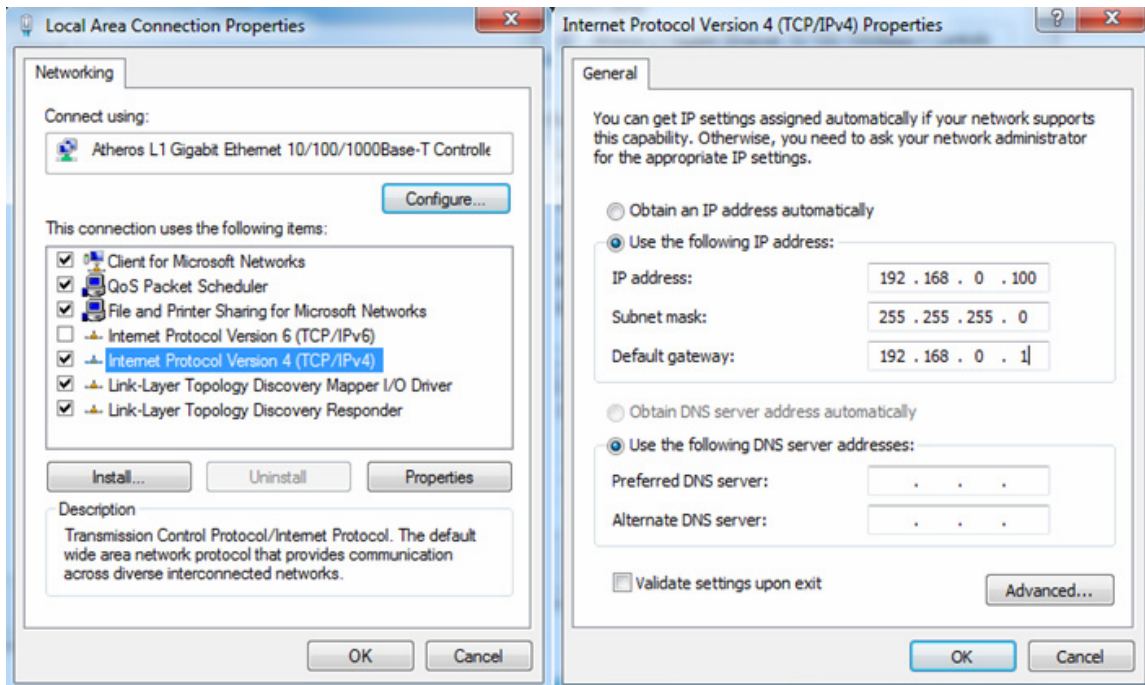

(6) A quick way to access remote monitoring is to left-click the mouse twice on a selected IP Camera listed on "Device list" of PLANET IP Installer. An IE browser will be opened.

(7) Then, please key in the default "**Username: admin**" and "**Password: admin**" in the following message box.

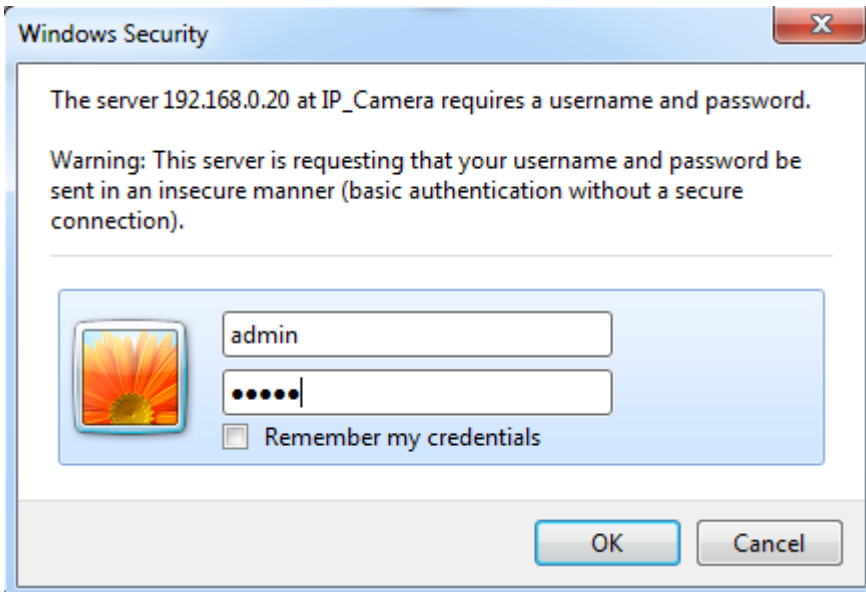

(8) If the user name and password are input correctly, the following web page will be displayed.

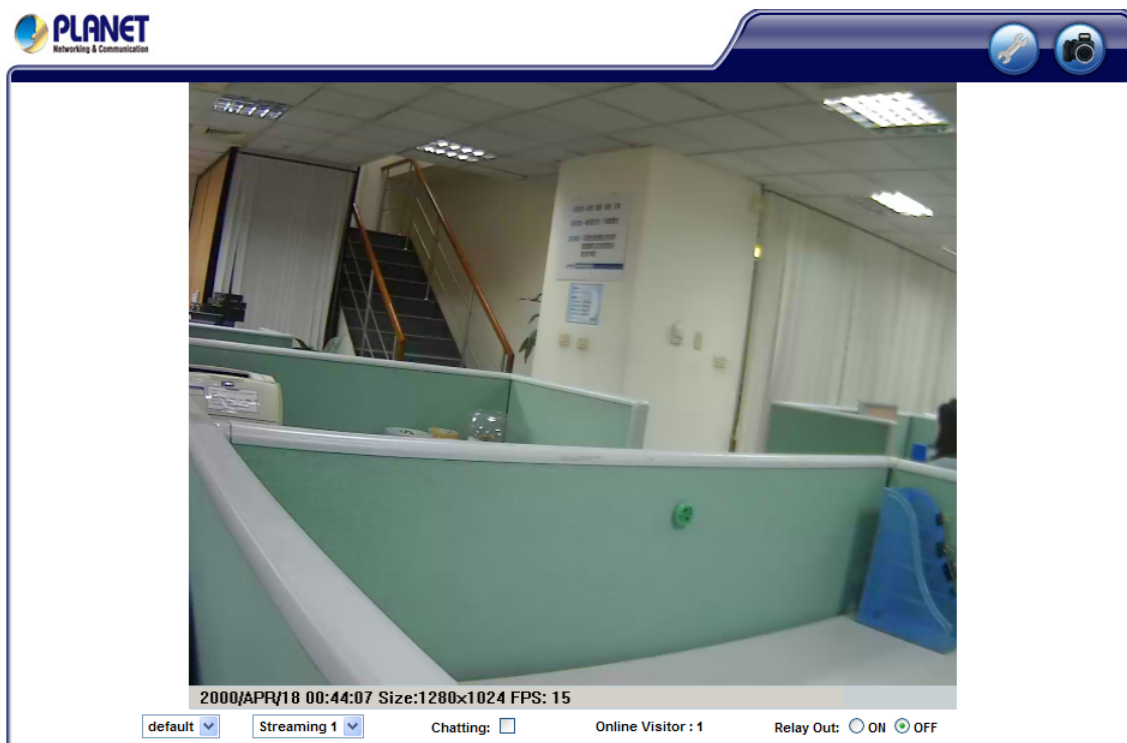

2.6 Setup ActiveX to use the Internet Camera

The Internet camera web pages communicate with the Internet camera using an ActiveX control. The ActiveX control must be downloaded from the Internet camera and installed on your PC. Your Internet Explorer security settings must allow for the web page to work correctly. To use the Internet camera, user must setup his IE browser as follows:

2.6.1 Internet Explorer 6 for Windows XP

From your IE browse → "Tools" → "Internet Options..." → "Security" → "Custom Level...", please setup your "Settings" as follow.

Set the first 3 items

- *Download the signed ActiveX controls*
- *Download the unsigned ActiveX controls*
- *Initialize and script the ActiveX controls not masked as safe to Prompt*

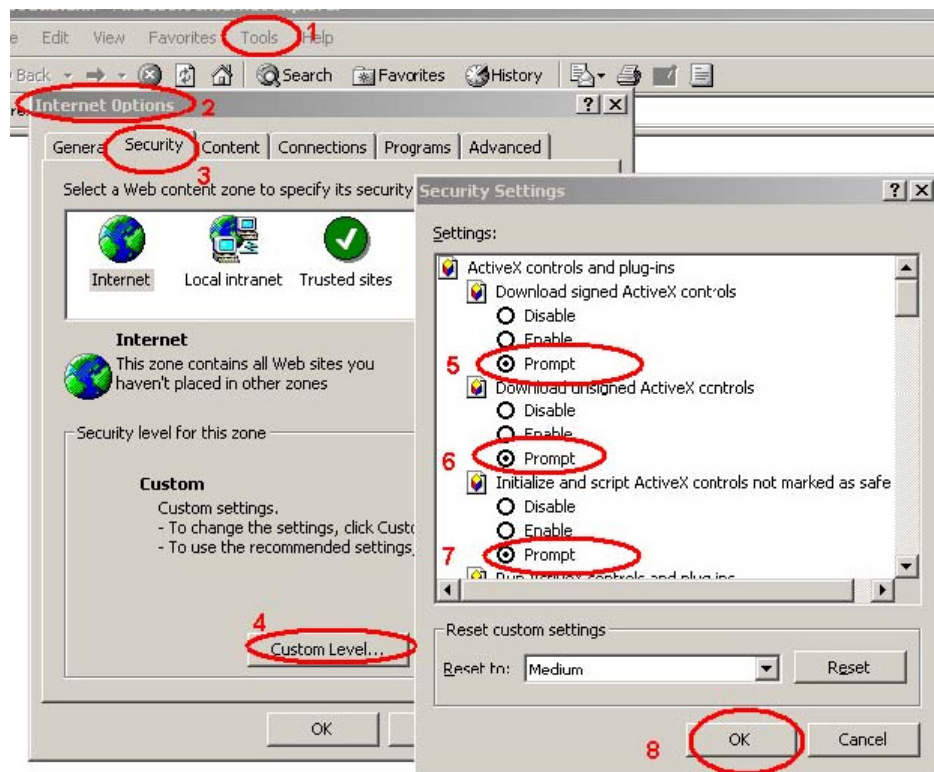

By now, you have finished your entire PC configuration for Internet camera.

2.6.2 Internet Explorer 7 for Windows XP

From your IE browse → "Tools" → "Internet Options..." → "Security" → "Custom Level...", please setup your "Settings" as follow.

Set the first 3 items

- *Allow previously unused ActiveX control to run...*
- *Allows Script lets*
- *Automatic prompting for ActiveX controls*

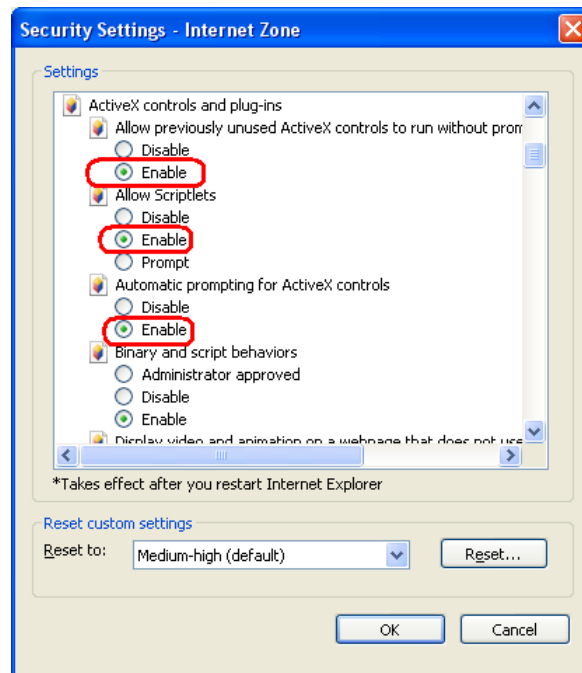

By now, you have finished your entire PC configuration for Internet camera.

2.6.3 Internet Explorer 7 for Windows Vista

From your IE browse → "Tools" → "Internet Options..." → "Security" → "Internet" → "Custom Level...", please setup your "Settings" as follow.

- Enable "Automatic prompting for ActiveX controls"
- Prompt "Initialize and script active controls not marked...."

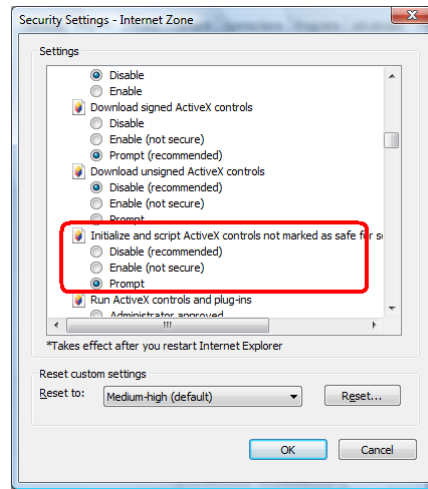
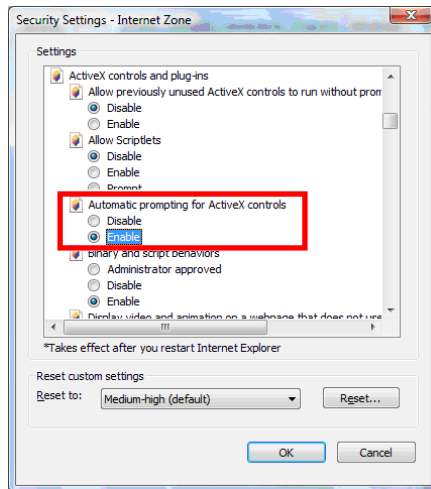

From your IE browse → "Tools" → "Internet Options..." → "Security" → "Trusted Sites" → "Custom Level...", please setup your "Settings" as follow.

- Enable "Automatic prompting for ActiveX controls"
- Prompt "Initialize and script active controls not marked...."

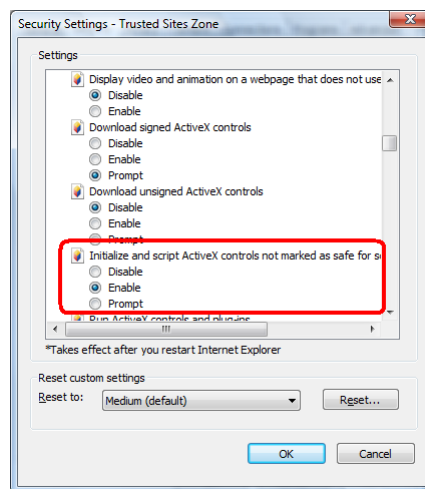
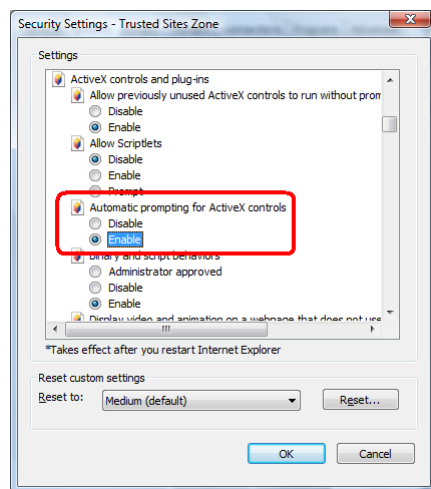

By now, you have finished your entire PC configuration for Internet camera.

3. Web-based Management

This chapter provides setup details of the Internet camera's Web-based Interface.

3.1 Introduction

The internet camera can be configured with your Web Browser. Before configure, please make sure your PC is under the same IP segment with Internet camera.

3.2 Connecting to Internet Camera

- Use the following procedure to establish a connection from your PC to the camera.
- Once connected, you can add the camera to your Browser's Favorites or Bookmarks.

Start the web browser on the computer and type the IP address of the camera. The Default IP: "<http://192.168.0.20>"

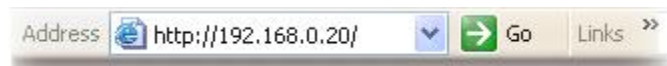

The login window of Internet camera will appear, Default login **username/password** is: **admin/ admin**



NOTE: If the User name and Password have been changed with PLANET IP Installer, please enter the new User name and Password here.

Web browser may display the “Security Warning” window, select “Yes” to install and run the ActiveX control into your PC.

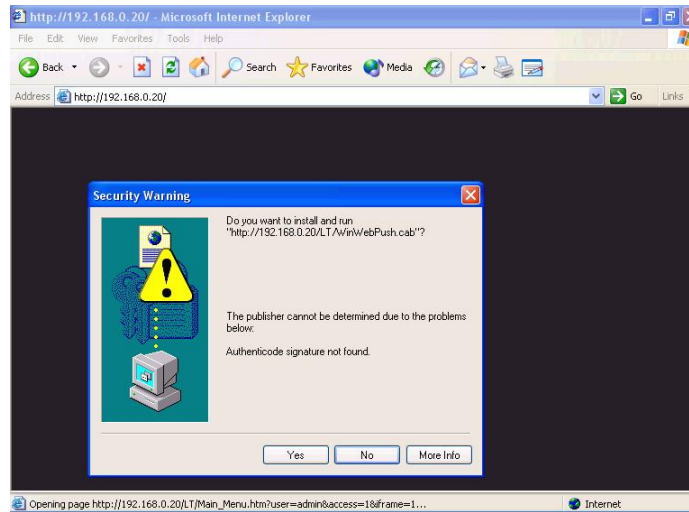

After the ActiveX control was installed and run, the first image will be displayed.

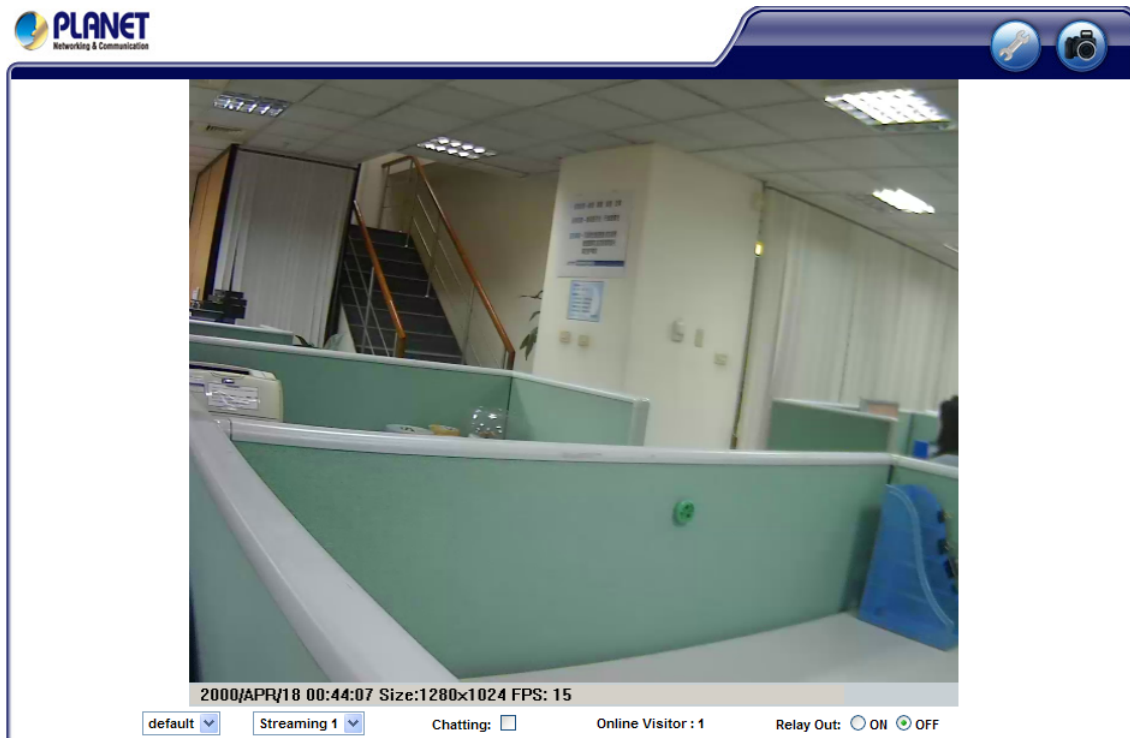



NOTE: If you log in the camera as an ordinary user, setting function will be not available. If you log in the camera as the administrator, you can perform all the settings provided within the device.

4. Live View

Start-up screen will be as follow no matter an ordinary users or an administrator.



(1)Configure	 Get into the administration page.
(2)Snapshot	 Video Snapshot
(3)Status Bar	Show system time, video resolution, and video refreshing rate.
(4)Screen Size	Select video screen “ default, 1/2x, 1x, 2x ” for view currently camera screen size.
(5)Streaming Select	Select video streaming source (When streaming 2 setting in 『Video Setting』 is closed, this function will not display)
(6)Chatting Function	IP Camera supports 2-way audio. Click the “ Chatting ” check box. Then you can use microphone which connects to the PC to talk to server side, which is IP Camera side

(7)Online Visitor	Shows how many people connect to this IP camera.
(8)Relay Control	Control the relay which is connected to this camera.

Double-click the video; it will change to full screen mode. Press “**Esc**” or double-click the video again, it will change back to normal mode. Right-Click the mouse on the video, it will show a pop-up menu.

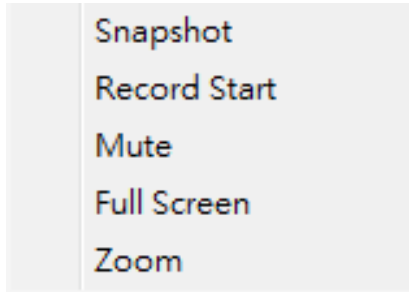

(1)Snapshot	Save a JPEG picture.
(2)Record Start	Record the video in the local PC. It will ask you where to save the video. To stop recording, right-click the mouse again. Select “ Record Stop ”. The video format is AVI. Use Microsoft Media Player to play the recorded file.
(3)Mute	Turn of the audio. Click again to turn on it.
(4)Full Screen	Full-screen mode.
(5)ZOOM	Enable zoom-in and zoom-out functions. Select “ Enable digital zoom ” option first within the pop-up dialogue box and then drag and drop the bar to adjust the zoom factors.

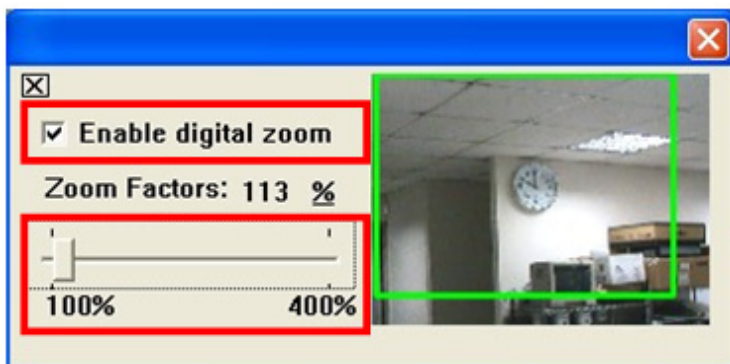

5. Configuration



Click

to get into the administration page. Click



to go back to the live video page.

PLANET
Networking & Communication

System Information

System Information

Server Information

MAC Address: 00:0F:0D:00:24:CF

Server Name: IP_Camera Status Bar

LED Indicator: ON OFF

Language: English 繁體中文 简体中文 French
 Russian Italian Spanish German
 Portuguese Polish

OSD Setting

Time Stamp: Enabled Disabled

Position: Top-Left Top-Right Bottom-Left Bottom-Right

Text: Enabled Disabled

Time Setting

Server Time: 2000/1/2 10:0:32 Time Zone: GMT+08:00

Date Format: yy/mm/dd mm/dd/yy dd/mm/yy

Time Zone: GMT+08:00

NTP:

NTP Server: 198.123.30.132

Update: 6 Hour

Time Shift: 0 Minutes [-1440..1440]

Synchronize with PC's time

Date: 2010/12/15

Time: 22:19:3

Manual

Date: 2010/12/15

Time: 22:19:3

The date and time remain the same

5.1 System

5.1.1 System Information

1. Server Information: Set up the camera name, select language, and set up the camera time.

System Information	
Server Information	
MAC Address:	<input type="text" value="00:30:4F:00:00:0F"/>
Server Name:	<input type="text" value="ICA-HM136"/> <input type="checkbox"/> Status Bar
LED Indicator:	<input checked="" type="radio"/> ON <input type="radio"/> OFF
Language :	<input checked="" type="radio"/> English <input type="radio"/> 繁體中文 <input type="radio"/> 简体中文 <input type="radio"/> French <input type="radio"/> Russian <input type="radio"/> Italian <input type="radio"/> Spanish <input type="radio"/> German <input type="radio"/> Portuguese <input type="radio"/> Polish

Server Name	This is the Camera name. This name will show on the IP Installer.
Select language	There are English, Traditional Chinese, and Simplified Chinese to select. When change, it will show the following dialogue box for the confirmation of changing language.



2. OSD Setting: Select a position where date & time stamp / text showing on screen.

OSD Setting	
Time Stamp:	<input type="radio"/> Enabled <input checked="" type="radio"/> Disabled
Text:	<input type="radio"/> Enabled <input checked="" type="radio"/> Disabled
	Test <u>Text Edit</u>

Moreover, click Text Edit can entry to adjust the OSD contents which is including Size and Alpha of text. Finally, click button to reserve the setting.

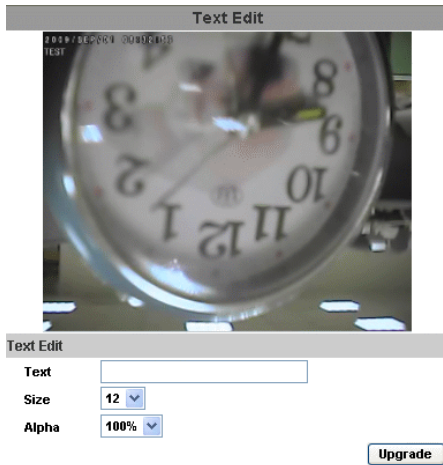

3. Server time setting : Select options to set up time - “NTP”, “Synchronize with PC’s time”, “Manual”, “The date and time remain the same”.

Time Setting

Server Time: 2000/1/2 10:22:26 Time Zone: GMT+08:00

Date Format: yy/mm/dd mm/dd/yy dd/mm/yy

Time Zone:

NTP :

NTP Server :

Update : Hour

Time Shift : Minutes [-1440..1440]

Synchronize with PC's time

Date :

Time :

Manual

Date :

Time :

The date and time remain the same

5.1.2 User Management

IP CAMERA supports three different users, administrator, general user, and anonymous user.

User Management

Anonymous User Login

YES NO

Add User

Username:

Password:

Confirm:

User List

Username	User Group	Modify	Remove
admin	Administrator	Edit	

Anonymous User Login	Yes : Allow anonymous login No : Need user name & password to access this IP camera
Add user	Type the user name and password, then click " Add/Set ".

Click "**edit**" or "**delete**" to modify the user

User Setup

Username:

Password:

Confirm:

5.1.3 System Update

System Update

Firmware Upgrade

Firmware Version: V1.0.18_PL

New Firmware:

Reboot System

Factory Default

Setting Management

Save As a File: Right click the mouse button on Setting Download and then select Save As to save current system's setting in the PC.

New Setting File:

Firmware Upgrade	To update the firmware online, click " Browse... " to select the firmware. Then click "Upgrade" to proceed.
Reboot System	Re-start the IP camera.
Factory default	Delete all the settings in this IP camera.
Setting Management	User may download the current setting to PC, or upgrade from previous saved setting.

Setting download:

Right-click the mouse button on Setting Download → Select "**Save AS...**" to save current IP CAM setting in PC → Select saving directory → Save

Upgrade from previous setting:

Browse → search previous setting → open → upgrade → Setting update confirm → click [index.html](#). to return to main page

5.2 Network

5.2.1 IP Setting

IP Camera supports DHCP and static IP.

IP Setting	
IP Assignment	
<input type="radio"/> DHCP <input checked="" type="radio"/> Static	
IP Address:	<input type="text" value="192.168.0.20"/>
Subnet Mask:	<input type="text" value="255.255.255.0"/>
Gateway:	<input type="text" value="192.168.0.1"/>
DNS 0:	<input type="text" value="168.95.1.1"/>
DNS 1:	<input type="text" value="8.8.8.8"/>
Port Assignment	
Web Page Port:	<input type="text" value="80"/>
RTSP Port :	<input type="text" value="554"/>
RTP Start Port:	<input type="text" value="5000"/> [1024..10000]
RTP End port:	<input type="text" value="9000"/> [1025..10000]
UPnP	
UPnP:	<input checked="" type="radio"/> Enabled <input type="radio"/> Disabled
UPnP Port Forwarding:	<input type="radio"/> Enabled <input checked="" type="radio"/> Disabled
External Web Port:	<input type="text" value="80"/>
External RTSP Port:	<input type="text" value="554"/>

DHCP	Using DHCP, IP Camera will get all the network parameters automatically.
Static IP	Please type in IP address, subnet mask, gateway, and DNS manually.
Port Assignment	<p>User may need to assign different port to avoid conflict when setting up IP assignment.</p> <p>(1)Web Page Port: setup web page connecting port and video transmitting port (Default: 80)</p> <p>(2)RTSP Port: setup port for RTSP transmitting (Default: 554)</p> <p>(3)RTP Start and End Port: in RTSP mode, you may use TCP and UDP for connecting. TCP connection uses RTSP Port (554). UDP connection uses RTP Start and End Port.</p>

UPnP	<p>This IP camera supports UPnP, If this service is enabled on your computer, the camera will automatically be detected and a new icon will be added to “My Network Places.”</p> <p>Note: UPnP must be enabled on your computer.</p>
-------------	--

Please follow the procedure to activate UPnP

5.2.2 Using UPnP of Windows XP or Vista

5.2.2.1 Windows XP

UPnP™ is short for Universal Plug and Play, which is a networking architecture that provides compatibility among networking equipment, software, and peripherals. This device is an UPnP enabled device. If the operating system, Windows XP, of your PC is UPnP enabled, the device will be very easy to configure. Use the following steps to enable UPnP settings only if your operating system of PC is running Windows XP.

NOTE: Windows 2000 does not support UPnP feature.

Go to **Start > Settings**, and Click Control Panel

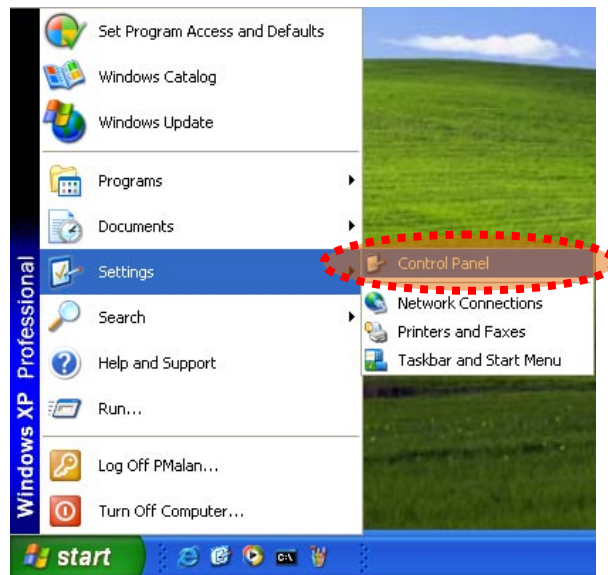

The “Control Panel” will display on the screen and double click “Add or Remove Programs” to continue

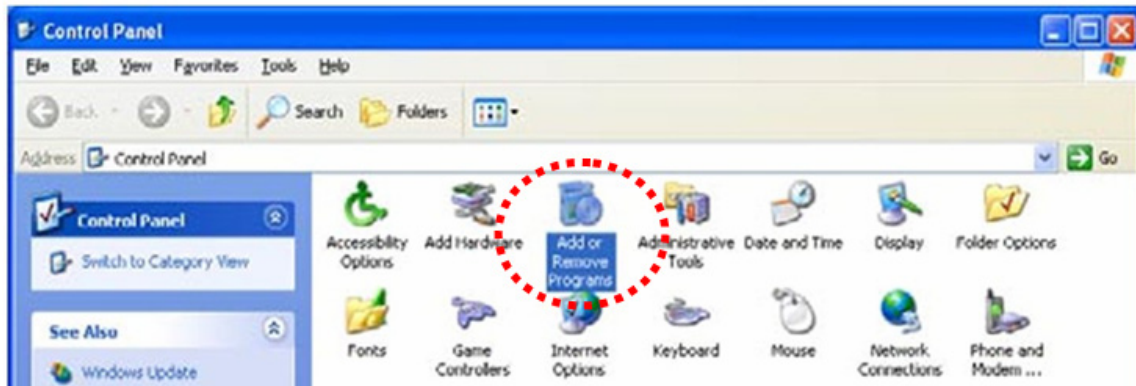

The “Add or Remove Programs” will display on the screen and click **Add/Remove Windows Components** to continue.

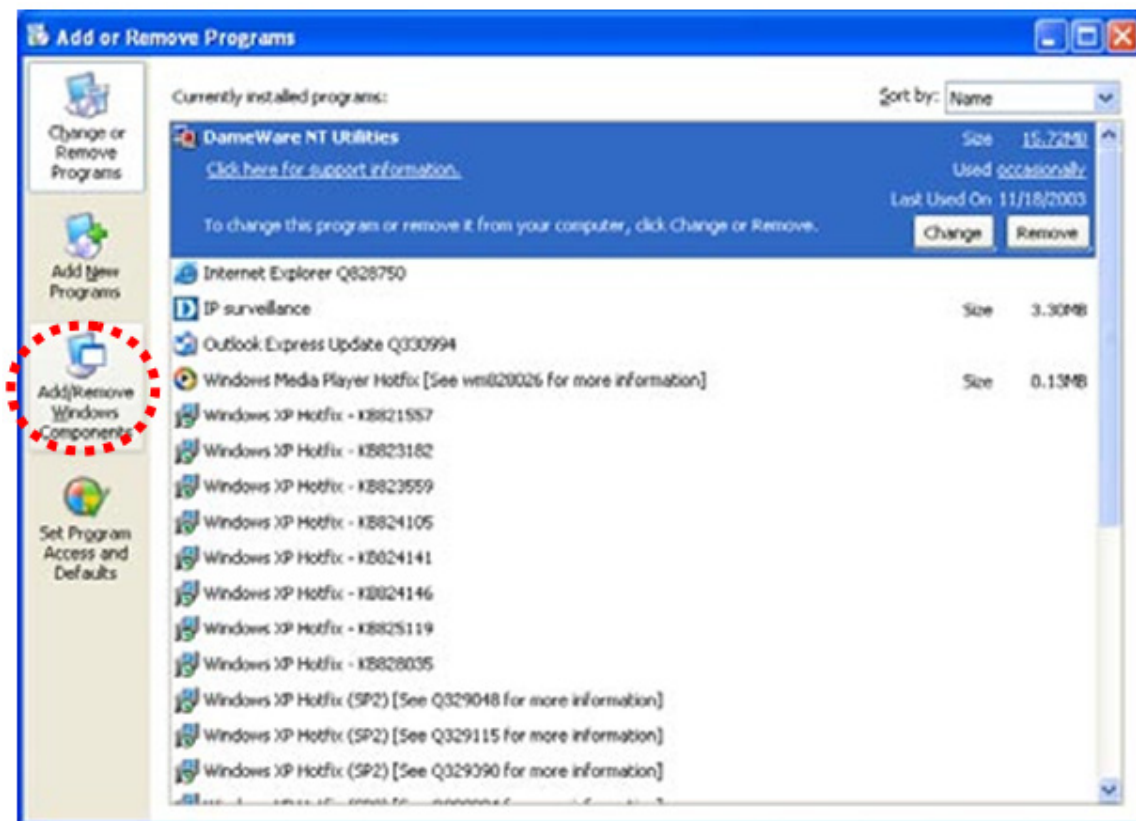

The following screen will appear, select “**Networking Services**” and click “**Details**” to continue

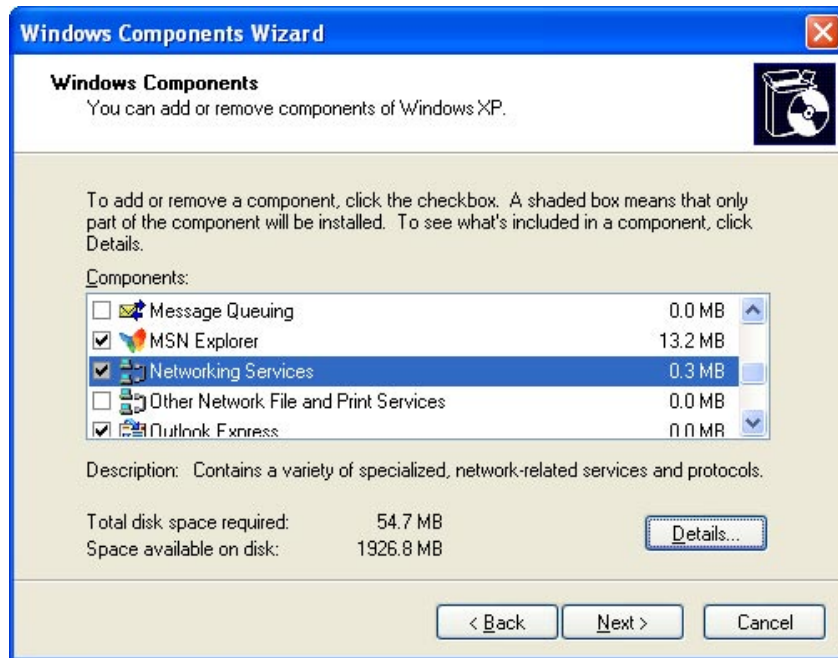

The “**Networking Services**” will display on the screen, select “**Universal Plug and Play**” and click “**OK**” to continue.

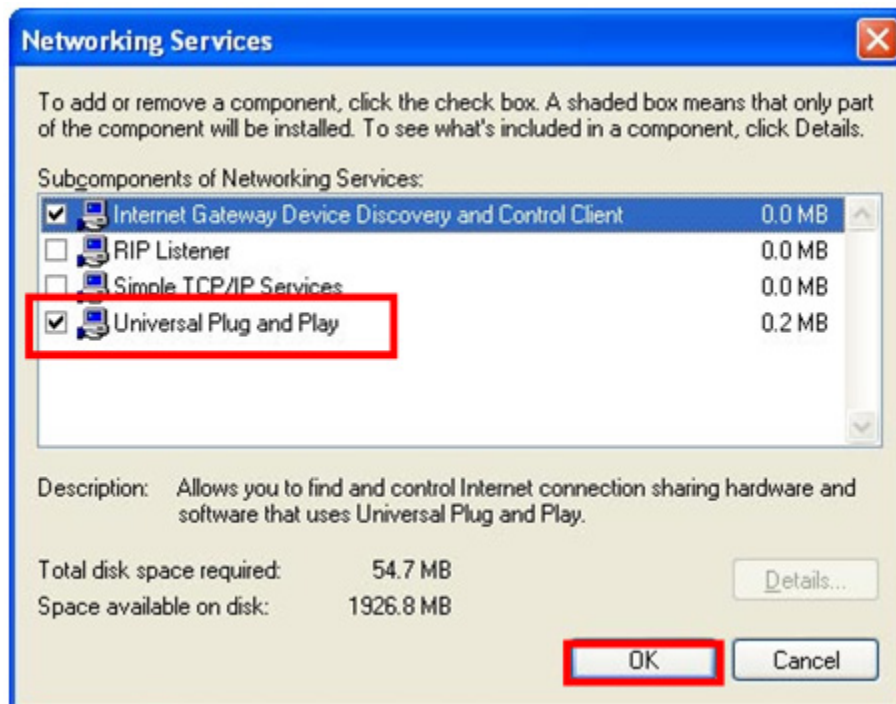

Please click “Next” to continue

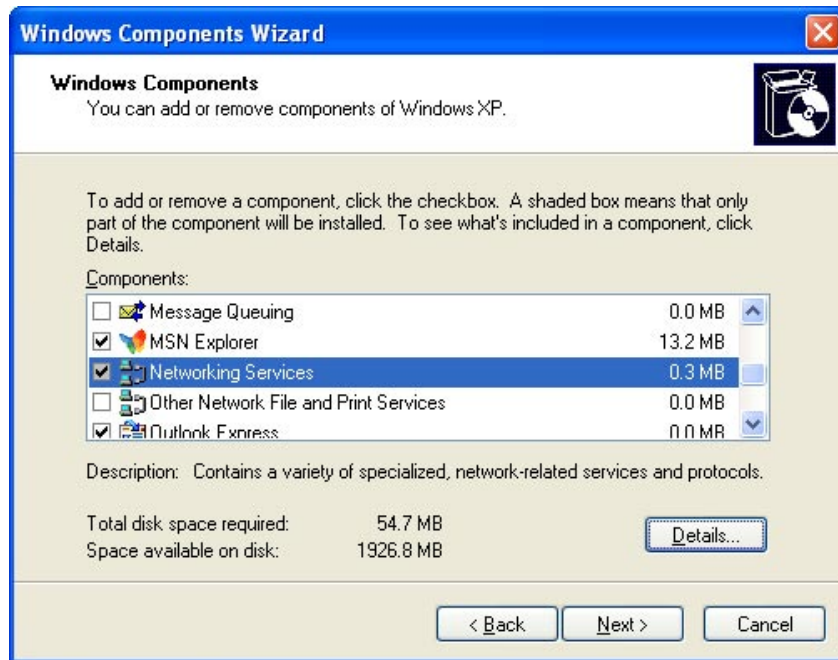

The program will start installing the UPnP automatically. You will see the below pop-up screen, please wait while Setup configures the components.

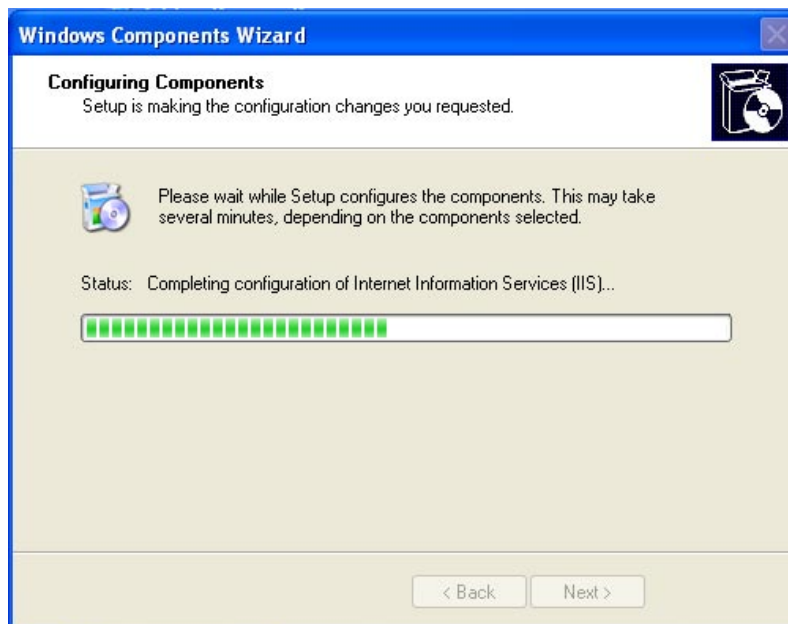

Please click **“Finish”** to complete the UPnP installation



Double-click **“My Network Places”** on the desktop, the **“My Network Places”** will display on the screen and double-click the UPnP icon with Internet camera to view your device in an internet browser.

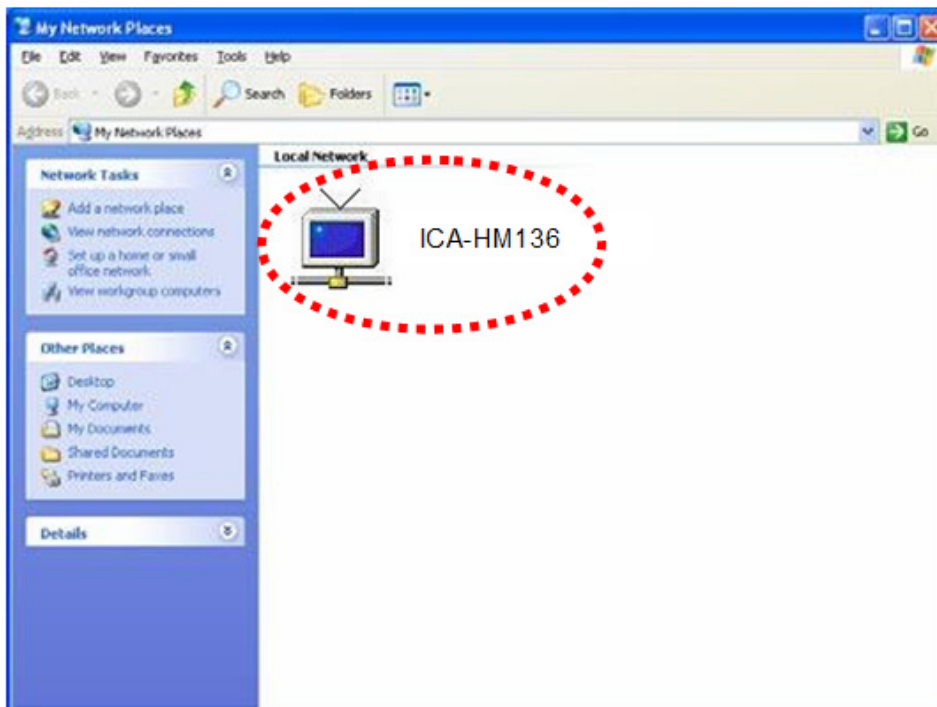

5.2.2.2 Windows Vista

UPnP™ is short for Universal Plug and Play, which is a networking architecture that provides compatibility among networking equipment, software, and peripherals. This device is an UPnP enabled device. If the operating system, Windows Vista, of your PC is UPnP enabled, the device will be very easy to configure. Use the following steps to enable UPnP settings only if your operating system of PC is running Windows Vista.

Go to **Start > Control Panel > Network and Internet > Network and Sharing Center**, and turn on **“Network Discovery”**.

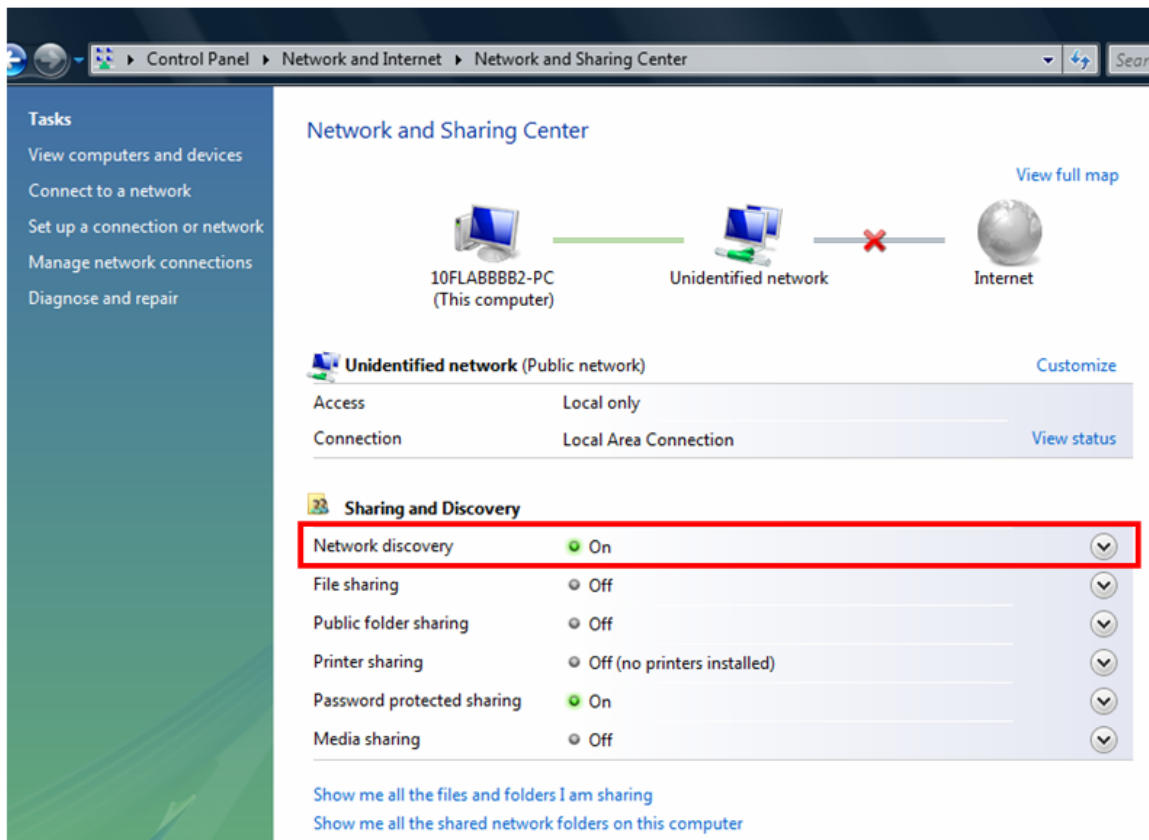

Double-click “**My Network Places**” on the desktop, the “**My Network Places**” will display on the screen and double-click the UPnP icon with Internet camera to view your device in an internet browser.

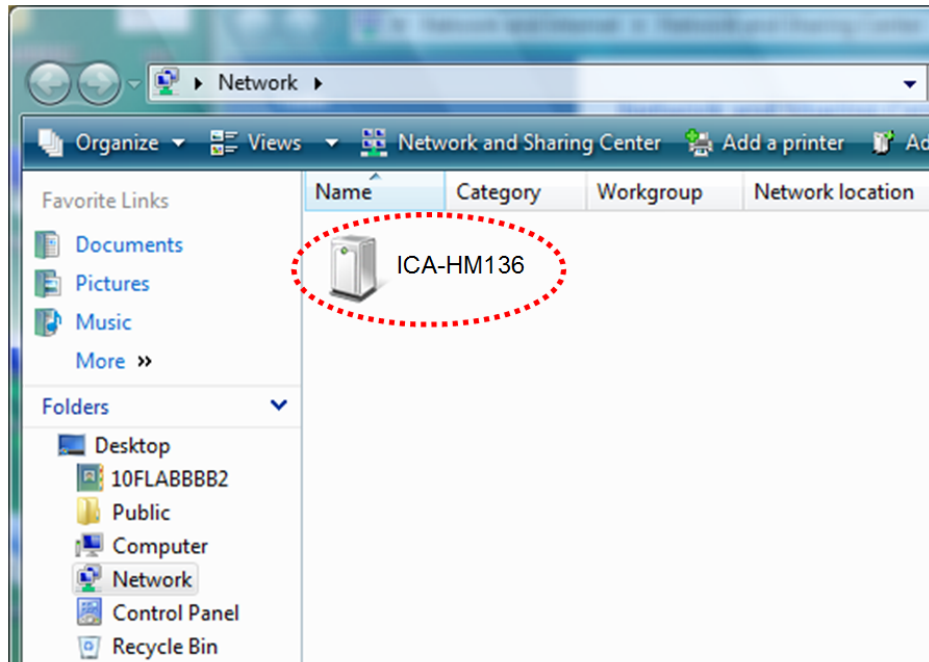

5.2.3 PPPoE

PPPoE: Stands for Point to Point Protocol over Ethernet

A standard builds on Ethernet and Point-to-Point network protocol. It allows Internet camera connect to Internet with xDSL or cable connection; it can dial up your ISP and get a dynamic IP address. For more PPPoE and Internet configuration, please consult your ISP.

It can directly connect to the xDSL, however, it should be setup on a LAN environment to program the PPPoE information first, and then connect to the xDSL modem. Power on again, then the device will dial on to the ISP connect to the WAN through the xDSL modem.

The procedures are:

- (1) Select “**Enabled**” to use PPPoE.
- (2) Key-in Username and password for the ADSL connection.
- (3) Send mail after dialed : When connect to the internet, it will send a mail to a specific mail account. For the mail setting, please refer to “**Mail and FTP**” settings.

PPPoE

PPPoE Setting

Enabled Disabled

Username:

Password:

Send mail after dialed

Enabled

Subject:

5.2.4 DDNS

DDNS: Stands for Dynamic Domain Name Server

The device supports DDNS If your device is connected to xDSL directly, you might need this feature. However, if your device is behind a NAT router, you will not need to enable this feature. Because DDNS allows the device to use an easier way to remember naming format rather than an IP address. The name of the domain is like the name of a person, and the IP address is like his phone number. On the Internet we have IP numbers for each host (computer, server, router, and so on), and we replace these IP numbers to easy remember names, which are organized into the domain name. As to xDSL environment, most of the users will use dynamic IP addresses. If users want to set up a web or a FTP server, then the Dynamic Domain Name Server is necessary. For more DDNS configuration, please consult your dealer.

Your Internet Service Provider (ISP) provides you at least one IP address which you use to connect to the Internet. The address you get may be static, meaning it never changes, or dynamic, meaning it's likely to change periodically. Just how often it changes, depends on your ISP. A dynamic IP address complicates remote access since you may not know what your current WAN

IP address is when you want to access your network over the Internet. The solution to the dynamic IP address problem comes in the form of a dynamic DNS service.

The Internet uses DNS servers to lookup domain names and translates them into IP addresses. Domain names are just easy to remember aliases for IP addresses. A dynamic DNS service is unique because it provides a means of updating your IP address so that your listing will remain current when your IP address changes. There are several excellent DDNS services available on the Internet and best of all they're free to use. One such service you can use is www.DynDNS.org. You'll need to register with the service and set up the domain name of your choice to begin using it. Please refer to the home page of the service for detailed instructions or refer to Appendix E for more information.

DDNS

DDNS Setting

Enabled Disabled

Provider:

Hostname:

Username:

Password:

Schedule Update: Minutes

State

Idle

Note:

1. **Schedule Update:** Depends on the input time of Schedule Update, it will update DDNS's web site automatically. The time range is from 5 to 5000 minutes.
*0: It will not update.
2. **dyndns.org & 3322.org:** Update once per day is recommended (1440 minutes per day). If updated too frequently, it will be blocked.

DynDns.org, the procedures are:

- (1) Enable this service
- (2) Key-in the DynDNS server name, user name, and password.
- (3) Set up the IP Schedule update refreshing rate.
- (4) Click "**Apply**"
- (5) If setting up IP schedule update too frequently, the IP may be blocked. In general, schedule update every day (1440 minutes) is recommended.

Camddns, the procedures are:

- (1) Please enable this service
- (2) Key-in user name.
- (3) IP Schedule update is default at 5 minutes
- (4) Click "**Apply**".

DDNS

DDNS Setting

Enabled Disabled

Provider:

Username:

Schedule Update: Minutes

State

Idle

Note:

- 1. Schedule Update:** Depends on the input time of Schedule Update, it will update DDNS's web site automatically. The time range is from 5 to 5000 minutes.
*0: It will not update.
- 2. dyndns.org & 3322.org:** Update once per day is recommended (1440 minutes per day). If updated too frequently, it will be blocked.

DDNS Status

- (1) Updating : Information update
- (2) Idle : Stop service
- (3) DDNS registration successful, can now log by <http://<username>.ddns.camddns.com> : Register successfully.
- (4) Update Failed, the name is already registered : The user name has already been used. Please change it.
- (5) Update Failed, please check your internet connection : Network connection failed.
- (6) Update Failed, please check the account information you provide : The server, user name, and password may be wrong.

5.2.5 Mail & FTP

To send out the video via mail of ftp, please set up the configuration first.

Mail & FTP	
Mail Setting	
Login Method:	Account ▼
Mail Server:	<input type="text"/>
Username:	<input type="text"/>
Password:	<input type="text"/>
Sender's Mail:	<input type="text"/>
Receiver's Mail:	<input type="text"/>
Bcc Mail:	<input type="text"/>
Mail Port:	25 (Default 25)
<input type="button" value="Test"/>	
FTP Setting	
FTP Server:	<input type="text"/>
Username:	<input type="text"/>
Password:	<input type="text"/>
Port:	21
Path:	/
Mode:	PORT ▼
Create the folder:	Yes ▼ (ex:Path/20100115/121032m.avi)
<input type="button" value="Test"/> <input type="button" value="Apply"/>	

5.3 A/V Setting

5.3.1 Image Setting

For the security purpose, there are three areas can be setup for privacy mask. Click “**Area**” button first and pull an area on the above image. Finally, click “**Save**” button to reserve the setting. Adjust “**Brightness**”, “**Contrast**”, “**Hue**”, “**Saturation**” to get clear video. Moreover, the ICA-HM136I supports “**Back Light Compensation(BLC)**”, “**Night Mode**” and “**Video Orientation**”.

Camera



Privacy Mask

Area 1**Area 2****Area 3**

Image Setting

Brightness:

Contrast:

Sharpness:

Back Light Compensation: ON OFF

Night Mode:

Video Orientation: Flip Mirror

5.3.2 Video Setting

User may select 2 streaming output simultaneously:

Streaming 1 Setting	Basic mode and Advanced mode.
Streaming 2 Setting	Basic mode, Advanced mode, and 3GPP mode

NOTE: Max Video Frame Rate for both streaming combined is 30 FPS.

Video System: click the drop down list to select the system type “NTSC/PAL”.

Video Setting

Video System:

Streaming 1 and 2 Basic Mode:

Streaming 1 Setting

Basic Mode **Advanced Mode**

Resolution:

Quality:

Video Frame Rate:

Video Format:

RTSP Path: **ex:rtsp://IP_Adress/ Audio:G.711**

Resolution	There are 8 resolutions can be chosen. 1600x 1200, 1280x1024, 1280x960, 1280x720, 800x600, 640x480, 320x240, 176x144
Quality	There are 5 levels to adjust: Best/ High/ Standard/ Medium/ Low The higher the quality is, the bigger the file size is. Also not good for internet transmitting
Video Frame Rate	The video refreshing rate per second.
Video Format	H.264 or JPEG.
RTSP Path	RTSP output name.

Streaming 1 and 2 Advanced Mode :

Streaming 1 Setting

Basic Mode **Advanced Mode**

Resolution: 1600x1200 ▾

Bitrate Control Mode: CBR **VBR**

Video Quantitative: 9 ▾

Video Bitrate: 8Mbps ▾

Video Frame Rate: 15 FPS ▾

GOP Size: 1 X FPS ▾ **GOP = 15**

Video Format: H.264 ▾

RTSP Path: **ex:rtsp://IP_Adress/ Audio:G.711**

Resolution	There are 8 resolutions can be chosen. 1600x 1200, 1280x1024, 1280x960, 1280x720, 800x600, 640x480, 320x240, 176x144
Bitrate Control Mode	There are CBR (Constant Bit Rate) and VBR (Variable Bit Rate) to use. CBR : 32Kbps~4Mbps (the higher the CBR is, the better the video quality is) VBR : 1(Low) ~10(High) – Compression rate, the higher the compression rate, the lower the picture quality is; vise versa. The balance between VBR and network bandwidth will affect picture quality. Please carefully select the VBR rate to avoid picture breaking up or lagging.
Video Frame Rate	The video refreshing rate per second.
GOP Size	It means " Group of Pictures ". The higher the GOP is, the better the quality is.
Video Format	H.264 or JPEG.
RTSP Path	RTSP output name.

3GPP Streaming mode:

3GPP Streaming Setting

Enabled Disabled (Resolution=176x144, FPS=5, Format=MPEG4)

3GPP Path: ex:rtsp://IP_Address/3g Audio:AMR
ex:rtsp://IP_Address/3gx No Audio

Enable or Disable	Enable or Disable 3GPP Streaming.
3GPP Path	3GPP output name.

NOTE: 3GPP mode suggested setting: 176x144 resolutions, 5FPS, MPEG4 format.

5.3.3 Audio

The ICA-HM136 supports 2-way audio. User can send audio from ICA-HM136 Built-in mic to remote PC; User can also send audio from remote PC to ICA-HM136's external speaker.

(1)Audio from IP camera built-in mic to local PC: select “**Enable**” to start this function.

Audio

IP Camera to PC

Enabled Disabled

(2)Audio from local PC to ICA-HM136: Check “**chatting**” in the browsing page.

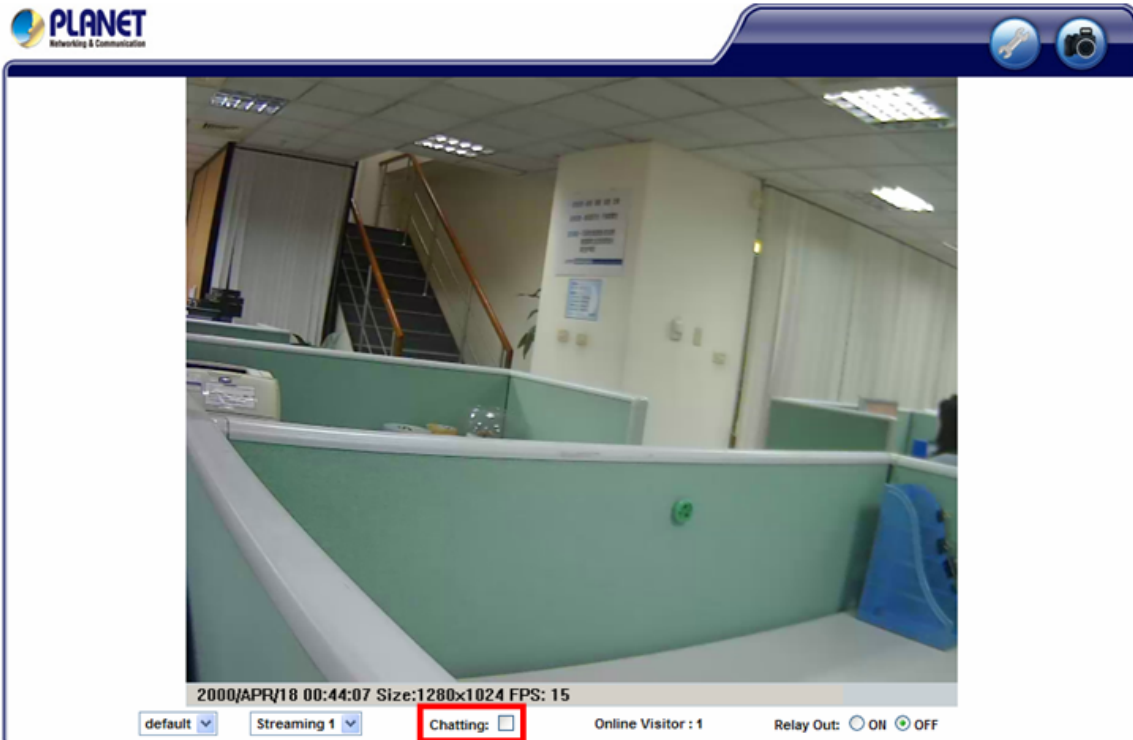

NOTE: The Audio will not be smooth when enable SD card recording function simultaneously.

5.4 Event List

The ICA-HM136 provides multiple event settings.

5.4.1 Event Setting

Event Setting

Motion Detection



Area Setting:	Area 1	Area 2	Area 3	
Sensitivity:	5	5	5	
<input type="checkbox"/> Area 1:	<input type="checkbox"/> E-mail	<input type="checkbox"/> FTP	<input type="checkbox"/> Out1	<input type="checkbox"/> Save to SD card
<input type="checkbox"/> Area 2:	<input type="checkbox"/> E-mail	<input type="checkbox"/> FTP	<input type="checkbox"/> Out1	<input type="checkbox"/> Save to SD card
<input type="checkbox"/> Area 3:	<input type="checkbox"/> E-mail	<input type="checkbox"/> FTP	<input type="checkbox"/> Out1	<input type="checkbox"/> Save to SD card

Subject:

Interval: a period of time between every two motions detected.

Based on the schedule

Record File

File Format:

Record Time Setting

Pre Alarm: **Post Alarm:**

Network Dis-connected

Dis-connected: Save to SD card

Network IP Check

IP Check: Enabled Disabled

IP Address:

Interval:

IP Check: Save to SD card

48

Motion Detection	IP CAMERA allows 3 areas motion detection. When motion is triggered, it can send the video to some specific mail addresses, transmit the video to remote ftp server, trigger the relay, and save video to local SD card. To set up the motion area, click "Area Setting". Using mouse to drag and draw the area. The same operation for area 2 and 3.
Record File Setting	IP CAMERA allows 3 different types of recording file to change its record size. When motion/alarm is triggered, there are 3 different types of record mode. (1)AVI File (With Record File Setting) (2)Multi-JPEG (With Record File Setting), only with JPEG compression format. (3)Single JPEG (Single File with Interval Setting)
Record Time Setting	Pre Alarm and Post Alarm setups for video start and end time when motion detected, I/O, or other devices got triggered. Note: Pre/Post Alarm record time is base on record time setting and IP Cam built-in Ram memory. Limited by IP Cam built-in Ram Memory, When information is too much or video quality set too high, it will cause recording frame drop or decrease on post alarm recording time.
Network Disconnected	When the network is down, it will save the video to local SD card. Note: This function is only enabled in wire connection.
Network IP check	When the connection is down, it records the video to SD card. Make sure the video recording is continuous. To use this function, key in the IP address of the PC which has recording software installed. Enable the function of "Save to SD card", then click "Apply". Note: The interval of two video files on SD card is fixed with 30 seconds.

5.4.2 Schedule

Schedule	After complete the schedule setup, the camera data will be recorded according to the schedule setup.
Snapshot	After enable the snapshot function, user can select the storage position of snapshot file, the interval time of snapshot and the reserved file name of snapshot.

Schedule																								
All	0	1	2	3	4	5	6	7	8	9	10	11	12	13	14	15	16	17	18	19	20	21	22	23
Mon.																								
Tue.																								
Wed.																								
Thu.																								
Fri.																								
Sat.																								
Sun.																								

With schedule setup.

Snapshot	
Enabled	<input type="radio"/> Enabled <input checked="" type="radio"/> Disabled
Snapshot:	<input type="checkbox"/> E-mail <input type="checkbox"/> FTP <input type="checkbox"/> Save to SD card
Interval:	<input type="text" value="10"/> Second(s) [1..50000]
File Name:	<input type="text" value="Snapshot"/>

5.4.3 I/O Setting

The ICA-HM136 supports 1 input/ 1 output. When input is triggered, it can send the video to some specific mail addresses, transmit the video to remote ftp server, trigger the relay, and save video to local SD card.

I/O Setting	
Input Setting	
Input 1 Sensor:	<input type="text" value="N.O"/>
Input 1 Action:	<input type="checkbox"/> E-mail <input type="checkbox"/> FTP <input type="checkbox"/> Out1 <input type="checkbox"/> Save to SD card
Subject:	<input type="text" value="GPIO In Detected!"/>
Interval:	<input type="text" value="10 sec"/>
	<input type="checkbox"/> Based on the <u>schedule</u>
Output Setting	
Mode Setting:	<input checked="" type="radio"/> OnOff Switch <input type="radio"/> Time Switch
Interval:	<input type="text" value="10 sec"/>

NOTE: Please connect to propriety relay box to reduce the risk of electric shock & damaged.

Alarm Input Setting	By GPIO I/O port input that provides related action while I/O input triggered.
GPIO Output Setting	By GPIO I/O port output that provides OnOff Switch, Slide Switch & Pan/Tilt Module for using with relay box.

GPIO pin define please refer to the part of Front / Back plane & I/O port pin assignment.

GPIO 0	ALARM INPUT Normal: 3.3V (The voltage differential from GPIO pin & GND) Active: 0V (GPIO 0 & GPIO1 link to PIN2 GND)
GPIO 1	
GPIO 2	ALARM OUTPUT Normal: 3.3V (The voltage differential from GPIO pin & GND) Active: 0V (GPIO 0 & GPIO1 link to PIN2 GND)
GPIO 3	

GPIO INSTALLATION EXAMPLE 1

Trigger a normal off (Normal Open) alarm siren on when event/motion occur at COM:

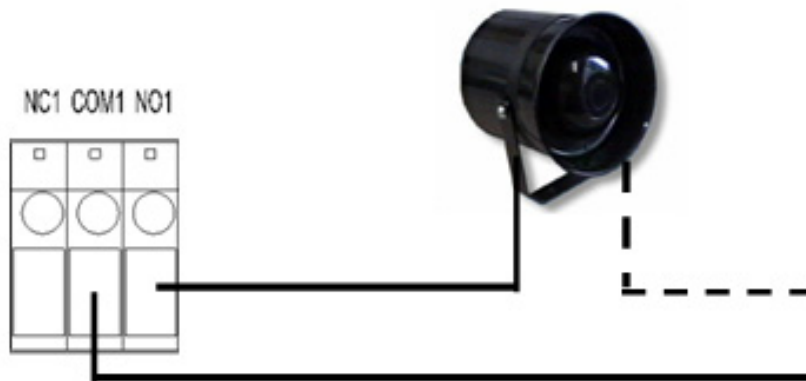

GPIO INSTALLATION EXAMPLE 2

Trigger the normal on (Normal Close) indoor illumination off when event / motion occur at COM:

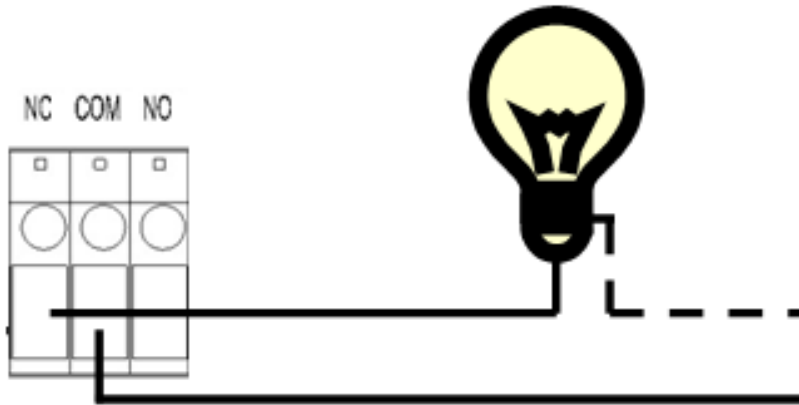

5.4.4 Log List

Sort by System Logs, Motion Detection Logs and I/O Logs. In addition, System Logs and I/O Logs won't lose data due to power failure.

Log List	
System Logs	Logs
Motion Detection Logs	Logs
I/O Logs	Logs
All Logs	Logs

5.4.5 SD Card

Please Insert SD cards before use it. Make sure pushing SD card into the slot completely.

Playback	
No SD card	
SD Management	
Auto Deletion:	<input type="text" value="Off"/> (Keep 1/ 2/ 3/ 4...days)
<input type="button" value="Apply"/>	

NOTE: The use of the SD card will affect the operation of the IP CAMERA slightly, such as affecting the frame rate of the video.

Playback, the procedures are:



- (1) It will show the capacity of the SD card. Click the date listed on this page. It will show the list of the video.
- (2) The video format is AVI. Click the video to start Microsoft Media Player to play it.
- (3) To delete the video, check it, and then click Del. When the SD card is full, it will remove the oldest video automatically.

2006/04/17			Del
Time	Video	Event Type	<input type="checkbox"/>
09:05:22	090522f.avi	Network Dis-connected	<input type="checkbox"/>
09:05:52	090552f.avi	Network Dis-connected	<input type="checkbox"/>
09:06:22	090622f.avi	Network Dis-connected	<input type="checkbox"/>
09:06:52	090652f.avi	Network Dis-connected	<input type="checkbox"/>
09:07:22	090722f.avi	Network Dis-connected	<input type="checkbox"/>
09:07:52	090752f.avi	Network Dis-connected	<input type="checkbox"/>
09:08:22	090822f.avi	Network Dis-connected	<input type="checkbox"/>
09:08:51	090851f.avi	Network Dis-connected	<input type="checkbox"/>
09:09:21	090921f.avi	Network Dis-connected	<input type="checkbox"/>
09:09:51	090951f.avi	Network Dis-connected	<input type="checkbox"/>

1 2 3 4 5

Appendix A: Factory Default

To recover the default IP address and password, please follow the following steps.

(1) Remove power, and press and hold the button in the back of IP CAMERA.



(2) Power on the camera. Don't release the button during the system booting.

(3) It will take around 30 seconds to boot the camera.

(4) Release the button when camera finishes proceed.

(5) Re-login the camera using the default IP (<http://192.168.0.20>), and username (admin), password (admin).

Appendix B: PING IP Address

The PING (stands for Packet Internet Groper) command is used to detect whether a specific IP address is accessible by sending a packet to the specific address and waiting for a reply. It's also a very useful tool to confirm Internet camera installed or if the IP address conflicts with any other devices over the network.

If you want to make sure the IP address of Internet camera, utilize the PING command as follows:

- Start a DOS window.
- Type ping x.x.x.x, where x.x.x.x is the IP address of the Internet camera.

The replies, as illustrated below, will provide an explanation to the problem.

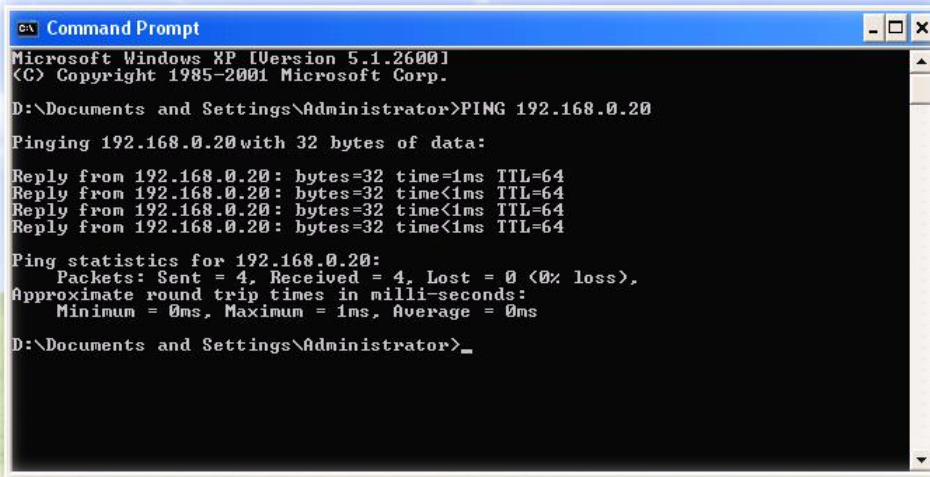

```
ca Command Prompt
Microsoft Windows XP [Version 5.1.2600]
(C) Copyright 1985-2001 Microsoft Corp.

D:\Documents and Settings\Administrator>PING 192.168.0.20

Pinging 192.168.0.20 with 32 bytes of data:

Reply from 192.168.0.20: bytes=32 time=1ms TTL=64
Reply from 192.168.0.20: bytes=32 time<1ms TTL=64
Reply from 192.168.0.20: bytes=32 time<1ms TTL=64
Reply from 192.168.0.20: bytes=32 time<1ms TTL=64

Ping statistics for 192.168.0.20:
    Packets: Sent = 4, Received = 4, Lost = 0 (0% loss),
    Approximate round trip times in milli-seconds:
        Minimum = 0ms, Maximum = 1ms, Average = 0ms

D:\Documents and Settings\Administrator>_
```

If you want to detect any other devices conflicts with the IP address of Internet camera, also can utilize the PING command but you must disconnect the Internet camera from the network first.

Appendix C: 3GPP Access

To use the 3GPP function, in addition to previous section, you might need more information or configuration to make this function work.

Note:	That to use the 3GPP function, it strongly recommends to install the Networked Device with a public and fixed IP address without any firewall protection.
--------------	---

RTSP Port:

Port 554 is the default for RTSP service. However, sometimes, some service providers change this port number for some reasons. If so, user needs to change this port accordingly.

Dialing procedure:

1. Choose a verified player (PacketVideo or Realplayer currently)
2. Use the following default URL to access:

rtsp://IP-Address/3g

Where *host* is the host name or IP address of the camera.

Compatible 3G mobile phone:

Please contact your dealer to get the approved list of compatible 3G phone.

Note:	Besides IP camera and 3G mobile phone. You will also need to make sure the ISP and company has provided the 3GPP service to you.
--------------	--

Appendix D: Bandwidth and Video Size Estimation

The frame rate of video transmitted from the Internet camera depends on connection bandwidth between client and server, video resolution, codec type, and quality setting of server. Here is a guideline to help you roughly estimate the bandwidth requirements for your Internet camera.

The required bandwidth depends on content of video source. The slow motion video will produce smaller bit rate generally and fast motion will produce higher bit rate vice versa. Actual results generated by the Internet camera may be varying.

Image Resolution	Average range of data sizes for M-JPEG mode	Average bit rate for MPEG-4 mode	Average bit rate for H.264 mode
160 x 120 (QQVGA)	3 ~ 6k byte per frame	64kbps~256kbps @ 30fps	32kbps~192kbps @ 30fps
320 x 240 (QVGA)	8 ~ 20k byte per frame	256kbps~768kbps @ 30fps	192kbps~512kbps @ 30fps
640 x 480 (VGA)	20 ~ 50K byte per frame	512kbps~2048kbps @ 30fps	384kbps~1536kbps @ 30fps
1280x1024 (SXGA)	100 ~ 200k byte per frame	NA	512kbps~3076kbps @ 15fps
1600x1200 (UXGA)	600 ~ 1500k byte per frame	NA	640kbps~6144kbps @ 15fps

NOTE:

Audio streaming also takes bandwidth around 5 kbps to 64kbps. Most xDSL/Cable modem upload speeds may not even reach up to 128 kbps. Thus, you may not be able to receive any video while streaming audio on a 128 kbps or lower connection. Even though the upload speed is more than 128kbps, for optimal video performance, disabling audio streaming will get better video performance.

Appendix E: DDNS Application

1. Preface

If you have a Cable modem or xDSL, this is a great way to host your own Networked Device or other TCP/IP Service. Get your own domain like www.yourname.com, www.yourname.com.tw etc. (Note: This domain must be registered with Internic via registration authorities such as Network Solutions, DirectNIC, Register.com etc). Your domain name's dynamic IP address is automatically tracked by a DDNS server.

Host your own Networked Device and much more no matter what your computer's IP address may be and even if you have dialup, DSL or cable modem internet connection where your computer's IP address changes all the time!! DDNS service supports all top level domain names including but not limited to .com, .net, .org, .to, .uk etc.

2. Ethernet Network Environment

Normally, DDNS service is only necessary for the users that could only obtain dynamic IP addresses. As to the users that could obtain the static valid IP address, they do not usually have to apply the DDNS service. Before we decide if DDNS is necessary for the users, we have to check what kind of Ethernet network environment we have to install our Networked Device on.

(1) Environment of Fixed Valid IP Network

If users could obtain valid IP addresses, they could save the effort to apply DDNS service. Because the IP address in this environment is fixed, users could input the IP address or domain name of demo site directly in the IE browser.

(2) Environment of Dynamic IP Network

If users is under an environment of dynamic IP network (Dial-up xDSL), they have to apply a domain name in advance. Then apply DDNS service. Finally setup the necessary information of DDNS and PPPoE of the Networked Device in order to let the outside administrator be able to access through internet.

3. Application Steps – DDNS & Domain Name

(1). Visit the following web site: <http://www.dyndns.org/>

(2). Click “Account”



(3). After the columns show up at the left side, click “Create Account”.

The screenshot shows the DynDNS website interface. At the top left is the DynDNS logo. Below it is a navigation menu with 'About', 'Services', and 'Account' tabs. On the left side, there is a 'My Account' section with a vertical list of links: 'Create Account', 'Login', and 'Lost Password?'. The 'Create Account' link is circled in red with a dashed border. Below this is a search box labeled 'Search DynDNS' with a 'Search' button. The main content area is titled 'Login' and contains a message: 'It is strongly recommended that you visit this page'. Below this is a form for 'Account Login' with a 'Username:' label and an input field. At the bottom of the main content area, there is a message: 'You must have cookies enabled'.

(4). Fill the application agreement and necessary information.

- a. Username
- b. E-mail address and confirmation
- c. Password and confirmation
- d. Submit all the input information and finish creating an account

The screenshot shows the 'Create Your DynDNS Account' page. At the top left is the DynDNS logo. On the right, there are 'User:' and 'Pass:' input fields. Below the logo is a navigation menu with 'About', 'Services', 'Account', 'Support', and 'News' tabs. On the left side, there is a 'My Account' section with a vertical list of links: 'Create Account', 'Login', and 'Lost Password?'. Below this is a search box labeled 'Search DynDNS' with a 'Search' button. The main content area is titled 'Create Your DynDNS Account' and contains a message: 'Please complete the form to create your free DynDNS Account.' Below this is a message: 'It is strongly recommended that you visit this page [securely](#). You are not currently visiting this page securely.' The form is titled 'User Information' and contains several input fields: 'Username:', 'E-mail Address:', 'Confirm E-mail Address:', 'Password:', and 'Confirm Password:'. A red dashed circle highlights the 'E-mail Address:', 'Confirm E-mail Address:', 'Password:', and 'Confirm Password:' fields. To the right of the 'E-mail Address:' field, there is a message: 'Instructions: activate your account will be sent to the e-mail address provided.' Below the 'Password:' field, there is a message: 'Your password needs to be more than 5 characters and cannot be the same as your username. Choose a password that is a common word, or can otherwise be easily guessed.'

Terms of Service

Please read the acceptable use policy (AUP) and accept it prior to creating your account. Also acknowledge that you may only have one (1) free account, and that creation of multiple free accounts will result in the deletion of all of your accounts.

Policy Last Modified: February 6, 2006

1. ACKNOWLEDGMENT AND ACCEPTANCE OF TERMS OF SERVICE

All services provided by Dynamic Network Services, Inc. ("DynDNS") are provided to you (the "Member") under the Terms and Conditions set forth in this Acceptable Use Policy ("AUP") and any other operating rules and policies set forth by DynDNS. The AUP comprises the entire agreement between the Member and DynDNS and supersedes all prior agreements between the parties regarding the subject matter contained herein. BY COMPLETING THE REGISTRATION PROCESS AND CLICKING THE "Accept" BUTTON, YOU ARE INDICATING YOUR AGREEMENT TO BE BOUND BY ALL OF THE TERMS AND CONDITIONS OF THE AUP.

2. DESCRIPTION OF SERVICE

I agree to the AUP:

I will only create one (1) free account:

Click these two options

Next Step

After you click "Create Account", we will create your account and send you an e-mail to the address you provided. Please follow the instructions in that e-mail to confirm your account. You will need to confirm your account within 48 hours or we will automatically delete your account. (This helps prevent unwanted robots on our systems)

Create Account

- (5). Check your e-mail mailbox. There will be an e-mail with a title "Your DynDNS Account Information". Click the hyperlink address to confirm the DDNS service that you just applied. Then DDNS you applied activated.

Click to confirm

Your DynDNS Account 'kkkkk' has been created. You need to visit the confirmation address below within 48 hours to complete the account creation process:

https://www.dyndns.com/account/confirm/oDDGDYN75qTJk_ICGba6vQ

Our basic service offerings are free, but they are supported by our paid services. See <http://www.dyndns.com/services/> for a full listing of all of our available services.

If you did not sign up for this account, this will be the only communication you will receive. All non-confirmed accounts are automatically deleted after 48 hours, and no addresses are kept on file. We apologize for any inconvenience this correspondence may have caused, and we assure you that it was only sent at the request of someone visiting our site requesting an account.

Sincerely,
The DynDNS Team

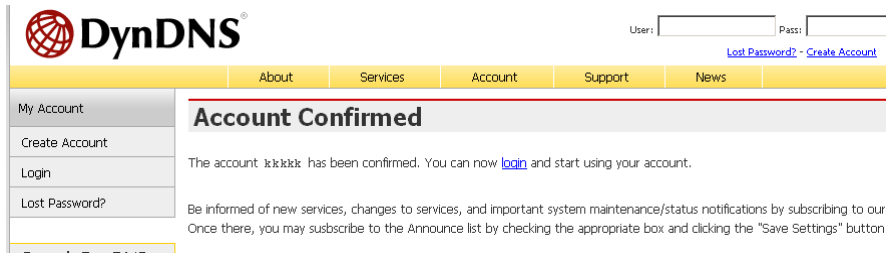

- (6). Enter the web page <http://www.dyndns.org/> again. Input your username and password that you just applied to login administration interface of DDNS server.



- (7). If the correct username and password are input, you can see the following picture at the top-right of the login page.

- (8). Click the "Services".



(9). Click the “ [Dynamic DNS](#) ”.

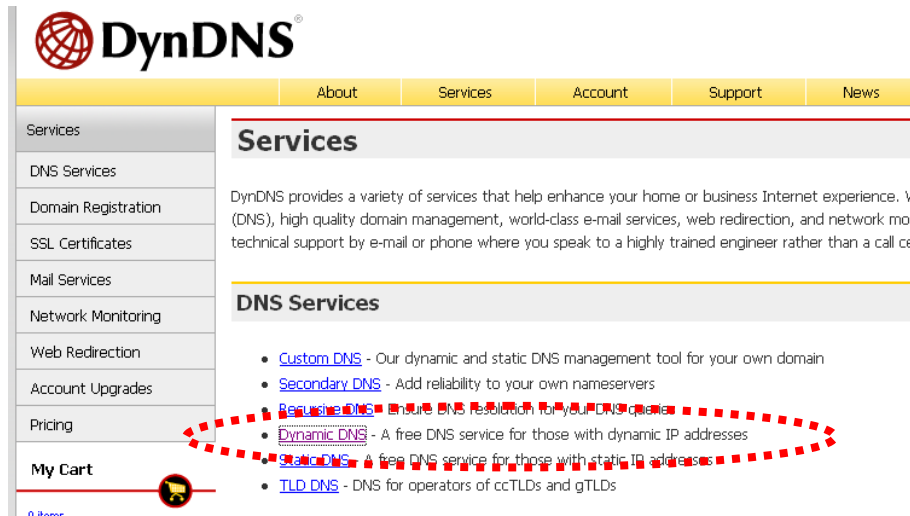

(10). Click the “ [Create Hosts](#) ”.

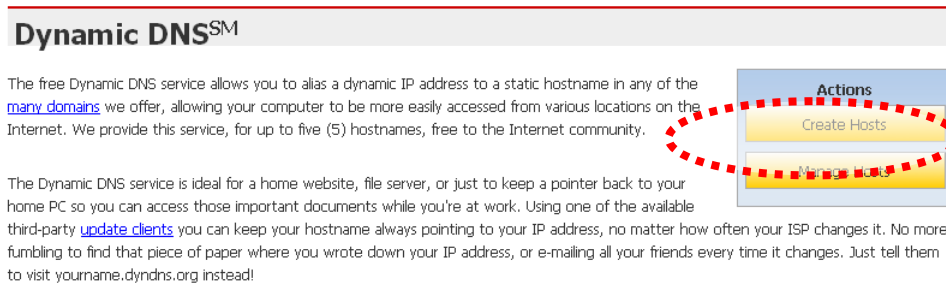

(11). We could create a domain name without any charge at this step. First, we input the host name. (No.1) Then we pick a domain that is easy to remember. Finally (No.2), click the “Add Host” to submit the domain name information. (No.3)

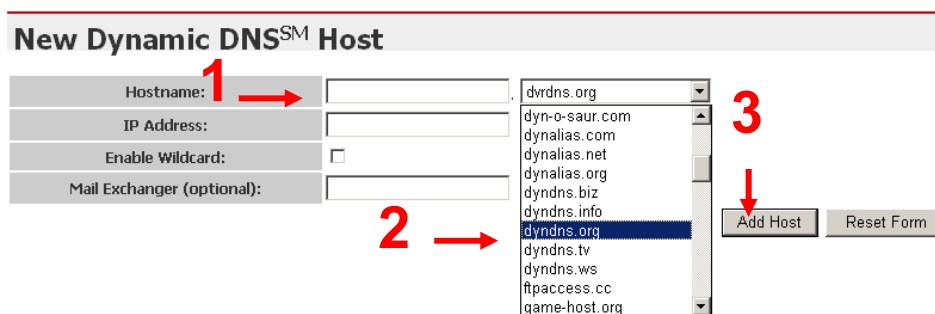

4. Setup the DDNS and PPPoE of Network Device

At last, users have to enter the web page of Networked Device and setup the necessary information of DDNS and PPPoE after the application of DDNS service. Please check the user manual to access the DDNS and PPPoE pages. After saving the modification, restart the device. The external users could browse the Networked Device by the input of their domain name.

Appendix F:

Configure Port Forwarding Manually

The device can be used with a router. If the device wants to be accessed from the WAN, its IP address needs to be setup as fixed IP address, also the port forwarding or Virtual Server function of router needs to be setup. This device supports UPnP traversal function. Therefore, user could use this feature to configure port forwarding of NAT router first. However, if user needs to configure port forwarding manually, please follow the steps as below:

Manually installing the device with a router on your network is an easy 3–step procedure as following:

1. Assign a local/fixed IP address to your device
2. Access the Router with Your Web browser
3. Open/Configure Virtual Server Ports of Your Router

1. Assign a local/fixed IP address to your device

The device must be assigned a local and fixed IP Address that allows it to be recognized by the router. Manually setup the device with a fixed IP address, for example, *192.168.0.100*.

2. Access the Router with Your Web browser

The following steps generally apply to any router that you have on your network. The PLANET WNRT-620 is used as an example to clarify the configuration process. Configure the initial settings of the router by following the steps outlined in the router's **Quick Installation Guide**.

If you have cable or DSL service, you will most likely have a dynamically assigned WAN IP Address. 'Dynamic' means that your router's WAN IP address can change from time to time depending on your ISP. A dynamic WAN IP Address identifies your router on the public network and allows it to access the Internet. To find out what your router's WAN IP Address is, go to the **Status** screen on your router and locate the WAN information for your router. As shown on the following page the WAN IP Address will be listed. This will be the address that you will need to type in your web browser to view your camera over the Internet. Be sure to uncheck the **Reset IP address at next boot** button at the top of the screen after modifying the IP address. Failure to do so will reset the IP address when you restart your computer.

PLANET Networking & Communication

Home | General Setup | Status | Tool

Internet Broadband Router

Status

- Internet Connection
- Device Status
- System Log
- Security Log
- Active DHCP Client
- Statistics

Current Time
1/1/2000 2:01:15

Internet Connection ⓘ

View the current internet connection status and related information.

Attain IP Protocol :	Dynamic IP disconnect
IP Address :	
Subnet Mask :	
Default Gateway :	0.0.0.0
MAC Address :	00:11:22:33:44:56
Primary DNS :	
Secondary DNS :	

Your WAN IP Address will be listed here.

3. Open/set Virtual Server Ports to enable remote image viewing

The firewall security features built into the router and most routers prevent users from accessing the video from the device over the Internet. The router connects to the Internet over a series of numbered ports. The ports normally used by the device are blocked from access over the Internet. Therefore, these ports need to be made accessible over the Internet. This is accomplished using the **Virtual Server** function on the router. The Virtual Server ports used by the camera must be opened through the router for remote access to your camera.

Follow these steps to configure your router's Virtual Server settings

- Click **Enabled**.
- Enter a unique name for each entry.
- Select **Both** under **Protocol Type (TCP and UDP)**
- Enter your camera's local IP Address (e.g., **192.168.0.100**, for example) in the **Private IP** field.
- If you are using the default camera port settings, enter **80** into the **Public and Private Port** section, click **Add**.

A check mark appearing before the entry name will indicate that the ports are enabled.

NOTE: Some ISPs block access to port 80. Be sure to check with your ISP so that you can open the appropriate ports accordingly. If your ISP does not pass traffic on port 80, you will need to change the port the camera uses from 80 to something else, such as 8080. Not all routers are the same, so refer to your user manual for specific instructions on how to open ports.

The screenshot shows the 'Virtual Server' configuration page on a Planet Internet Broadband Router. The page has a dark blue header with the Planet logo and navigation links: Home, General Setup, Status, and Tool. The main title is 'Internet Broadband Router'. On the left, a sidebar menu lists various settings: System, WAN, LAN, Wireless, QoS, NAT (selected), and Firewall. Under NAT, there are sub-links for Port Forwarding, Virtual Server (highlighted), Special applications, UPnP Setting, and ALG Settings. The main content area is titled 'Virtual Server' and includes a help icon. Below the title is a descriptive paragraph: 'You can configure the Broadband router as a Virtual Server so that remote users accessing services such as the Web or FTP at your local site via Public IP Addresses can be automatically redirected to local servers configured with Private IP Addresses. In other words, depending on the requested service (TCP/UDP) port number, the Broadband router redirects the external service request to the appropriate internal server (located at one of your LAN's Private IP Address).' There is a checkbox labeled 'Enable Virtual Server' which is checked. Below this is a form with columns: Private IP, Private Port, Type, Public Port, WAN Port, and Comment. The form contains input fields and dropdown menus. Below the form are 'Add' and 'Reset' buttons. A section titled 'Current Virtual Server Table:' contains a table with columns: Private IP, Private Port, Type, Public Port, WAN Port, Comment, and Select. The table has one row with the following data: Private IP: 192.168.0.100, Private Port: 80, Type: TCP+UDP, Public Port: 80, WAN Port: WAN1, Comment: ICA-HM230, and a checked 'Select' checkbox. Below the table are 'Delete Selected', 'Delete All', and 'Reset' buttons. At the bottom right of the page are 'Apply' and 'Cancel' buttons.

Enter valid ports in the **Virtual Server** section of your router. Please make sure to check the box on this line to enable settings. Then the device can be access from WAN by the router's WAN IP Address.

By now, you have finished your entire PC configuration for this device.

Appendix G: SD Card Recommended

SD Card Recommended :

SanDisk	128M
SanDisk	256M
SanDisk	512M
SanDisk	1GB
SanDisk	2GB
SanDisk	4GB
SanDisk	8GB
SanDisk	16GB
SanDisk	32GB
Transcend	4GB
Transcend	8GB
Transcend	16GB
Transcend	32GB

Appendix H: Troubleshooting & Frequently Asked Questions

Features	
The video and audio codec is adopted in the device.	<p>The device utilizes H.264, MPEG-4 and M-JPEG triple compression to providing high quality images. Where H.264 and MPEG-4 are standards for video compression and M-JPEG is a standard for image compression.</p> <p>The audio codec is defined as AMR for 3GPP and G.711 for RTSP streaming.</p>
The maximum number of user accesses the device simultaneously.	The maximum number of users is limited to 10. However, it also depends on the total bandwidth accessed to this device from clients.
Install this device	
The network cabling is required for the device.	The device uses Category 5 UTP cable allowing 10 and/or 100 Base-T networking.
The device will be installed and work if a firewall exists on the network.	If a firewall exists on the network, port 80 is open for ordinary data communication. The HTTP port and RTSP port need to be opened on the firewall or NAT router.
The username and password for the first time or after factory default reset	<p>Username = admin and Password = admin.</p> <p>Note that it's all case sensitivity.</p>
Forgot the username and password	<p>Follow the steps below.</p> <p>(1)Remove power, and press and hold the button in the back of IP CAMERA.</p> <p>(2)Power on the camera. Don't release the button during the system booting.</p> <p>(3)It will take around 30 seconds to boot the camera.</p> <p>(4)Release the button when camera finishes proceed.</p> <p>(5)Re-login the camera using the default IP (http://192.168.0.20), and username (admin), password (admin).</p>
Forgot the IP address of the device.	Check IP address of device by using the PLANET IP Installer program or by UPnP discovery or set the device to default by Reset button.
PLANET IP Installer program cannot find the device.	<ul style="list-style-type: none"> ● Re-power the device if cannot find the unit within 1 minutes. ● Do not connect device over a router. PLANET IP Installer program cannot detect device over a router. ● If IP address is not assigned to the PC which running PLANET IP Installer program, then PLANET IP Installer program cannot find device. Make sure that IP address is assigned to the PC properly.

	<ul style="list-style-type: none"> ● Antivirus software on the PC might interfere with the setup program. Disable the firewall of the antivirus software during setting up this device. ● Check the firewall setting of your PC or Notebook.
Internet Explorer does not seem to work well with the device	Make sure that your Internet Explorer is version 6.0 or later. If you are experiencing problems, try upgrading to the latest version of Microsoft's Internet Explorer from the Microsoft webpage.
PLANET IP Installer program fails to save the network parameters.	Network may have trouble. Confirm the parameters and connections of the device.
UPnP NAT Traversal	
Can not work with NAT router	Maybe NAT router does not support UPnP function. Please check user's manual of router and turn on UPnP function.
Some IP cameras are working but others are failed	Maybe too many IP cameras have been installed on the LAN, and then NAT router is out of resource to support more cameras. You could turn off and on NAT router to clear out of date information inside router.
Access this device	
Cannot access the login page and other web pages of the Network Camera from Internet Explorer	<ul style="list-style-type: none"> ● Maybe the IP Address of the Network Camera is already being used by another device or computer. To confirm this possible problem, disconnect the Network Camera from the network first, and then run the PING utility to check it out. ● Maybe due to the network cable. Try correcting your network cable and configuration. Test the network interface by connecting a local computer to the Network Camera via a crossover cable. ● Make sure the Internet connection and setting is ok. ● Make sure enter the IP address of Internet Explorer is correct. If the Network Camera has a dynamic address, it may have changed since you last checked it. ● Network congestion may prevent the web page appearing quickly. Wait for a while. <p>The IP address and Subnet Mask of the PC and Network Camera must be in the same class of the private IP address on the LAN.</p> <ul style="list-style-type: none"> ● Make sure the http port used by the Network Camera, default=80, is forward to the Network Camera's private IP address. ● The port number assigned in your Network Camera might not be available via Internet. Check your ISP for available port. ● The proxy server may prevent you from connecting directly to the Network Camera, set up not to use the proxy server. ● Confirm that Default Gateway address is correct. ● The router needs Port Forwarding feature. Refer to your router's

	<p>manual for details.</p> <ul style="list-style-type: none"> ● Packet Filtering of the router may prohibit access from an external network. Refer to your router's manual for details. ● Access the Network Camera from the Internet with the global IP address of the router and port number of Network Camera. ● Some routers reject the global IP address to access the Network Camera on the same LAN. Access with the private IP address and correct port number of Network Camera. ● When you use DDNS, you need to set Default Gateway and DNS server address. ● If it's not working after above procedure, reset Network Camera to default setting and installed it again.
<p>Image or video does not appear in the main page.</p>	<ul style="list-style-type: none"> ● The first time the PC connects to Network Camera, a pop-up Security Warning window will appear to download ActiveX Controls. When using Windows XP, or Vista, log on with an appropriate account that is authorized to install applications. ● Network congestion may prevent the Image screen from appearing quickly. You may choose lower resolution to reduce the required bandwidth.
<p>How to check the device's ActiveX is installed on your computer</p>	<p>Go to C:\Windows\Downloaded Program Files and check to see if there is an entry for the file "Web Watch2 Control". The status column should show "Installed". If the file is not listed, make sure your Security Settings in Internet Explorer are configured properly and then try reloading the device's home page. Most likely, the ActiveX control did not download and install correctly. Check your Internet Explorer security settings and then close and restart Internet Explorer. Try to browse and log in again.</p>
<p>Internet Explorer displays the following message: "Your current security settings prohibit downloading ActiveX controls".</p>	<p>Setup the IE security settings or configure the individual settings to allow downloading and scripting of ActiveX controls.</p>
<p>The device work locally but not externally.</p>	<ul style="list-style-type: none"> ● Might be caused from the firewall protection. Check the Internet firewall with your system or network administrator. The firewall may need to have some settings changed in order for the device to be accessible outside your LAN. ● Make sure that the device isn't conflicting with any other web server running on your LAN. ● Check the configuration of the router settings allow the device to be accessed outside your local LAN. ● Check the bandwidth of Internet connection. If the Internet bandwidth is lower than target bit rate, the video streaming will not work correctly.

The unreadable characters are displayed.	Use the operating system of the selected language. Set the Encoding or the Character Set of the selected language on the Internet Explorer.
Frame rate is slower than the setting.	<ul style="list-style-type: none"> • The traffic of the network and the object of the image affect the frame rate. The network congestion causes frame rate slower than the setting. • Check the bandwidth of Internet connection. If the Internet bandwidth is lower than target bit rate, the video streaming will not work correctly. • Ethernet switching hub can smooth the frame rate.
Blank screen or very slow video when audio is enabled.	<ul style="list-style-type: none"> • Your connection to the device does not have enough bandwidth to support a higher frame rate for the streamed image size. Try reducing the video streaming size to 160x120 or 320x240 and/or disabling audio. • Audio will consume 32 kbps. Disable audio to improve video. Your Internet connection may not have enough bandwidth to support streaming audio from the device.
Image Transfer on e-mail or FTP does not work.	<ul style="list-style-type: none"> • Default Gateway and DNS server address should be set up correctly. • If FTP does not work properly, ask your ISP or network administrator about the transferring mode of FTP server.
Video quality of the device	
The focus on the Camera is bad.	The lens is dirty or dust is attached. Fingerprints, dust, stain, etc. on the lens can degrade the image quality.
The color of the image is poor or strange.	<ul style="list-style-type: none"> • Adjust White Balance. • To insure the images you are viewing are the best they can be, set the Display property setting (color quality) to 16bit at least and 24 bit or higher if possible within your computer. • The configuration on the device image display is incorrect. You need to adjust the image related parameters such as brightness, contrast, hue and sharpness properly.
Image flickers.	<ul style="list-style-type: none"> • If the object is dark, the image will flicker. Make the condition around the Camera brighter.

Appendix I: Product Specification

Product	ICA-HM136
Video Specification	
Image Device	1/3.2" 2Mega-Pixel CMOS Sensor
Effective Pixels	1600 x 1200 pixels
Sensitivity	0.5lux
Lens	2.7mm – 9mm Vari-focal lens with auto iris and IR cut filter
Illuminator	0 Lux IR on
View Angle	H: 30.4~101 Degree / V: 23~75 Degree
Video Encoder	H.264, MPEG4 and Motion JPEG simultaneously (Tri-encoders)
Video Profile	12 profiles simultaneously - H.264 UXGA / 720p / SXGA / VGA / QVGA / QCIF - M-JPEG UXGA / 720p / SXGA / VGA / QVGA - MPEG4 QCIF (Only for 3GPP)
Frame Rate	UXGA Up to 15fps SXGA Up to 22fps HD-720p / SVGA / VGA / QVGA / QCIF Up to 30fps
Image Setting	Brightness, sharpness, contrast, AGC, BLC, Night Mode Text, time and date overlay
Streaming	Simultaneously multi-profile streaming M-JPEG streaming over HTTP Supports 3GPP mobile surveillance Controllable frame rate and bandwidth Constant and variable bit rate (MPEG4 / H.264)
Audio Specification	
Audio Encoder	RTSP:G.711 3GPP:AMR
Audio Streaming	One-way or Two-way
Microphone	External microphone input
Audio Output	Phone Jack
Network Specification	
Supported Protocols	TCP, UDP, HTTP, SMTP, FTP, NTP, DNS, DDNS, DHCP, UPnP, RTSP, RTP, RTCP, PPPoE, 3GPP, ICMP
Security	Password protection, user access log
Users	10 simultaneous unicast users
Ethernet	10/100M auto negotiation
System Integration	
Application Programming Interface	Open API for software integration SDK
Alarm Triggers	Intelligent video motion detection and external input
Motion Detection	3-zone video motion detection
Alarm Events	File upload via FTP, email and save to MicroSD Card External output activation
Video Buffer	Pre- 5sec and post- 10 sec alarm buffering
General	
Power Supply	12V DC external power adapter
PoE	IEEE 802.3af
PoE Consumption	Max 9 W while IR LED ON Max 7 W while IR LED OFF
Connectors	RJ-45 10BaseT/100BaseTX , DC jack

Illumination LED	IR LEDS
IR LED	Infrared LED ×18pcs
IR Wavelength	850nm
IR Distance	15M
Operating Temperature	-10 ~ 40 degree C
Viewing System	
OS	Windows® XP, Vista 32bit, Win7 32bit, Server 2003
Browser	IE 6.0 or latter
Cell Phone	With 3GPP player
Video Player	VLC, Quick Time, Real Player
Software	
Monitor/ Recording / Management	CV3P (2-ch Cam Viewer Three Pro Trail Version) CV3L (64-ch Cam Viewer Three Lite Bundle Version)
Search & Installation	PLANET IP Installer