

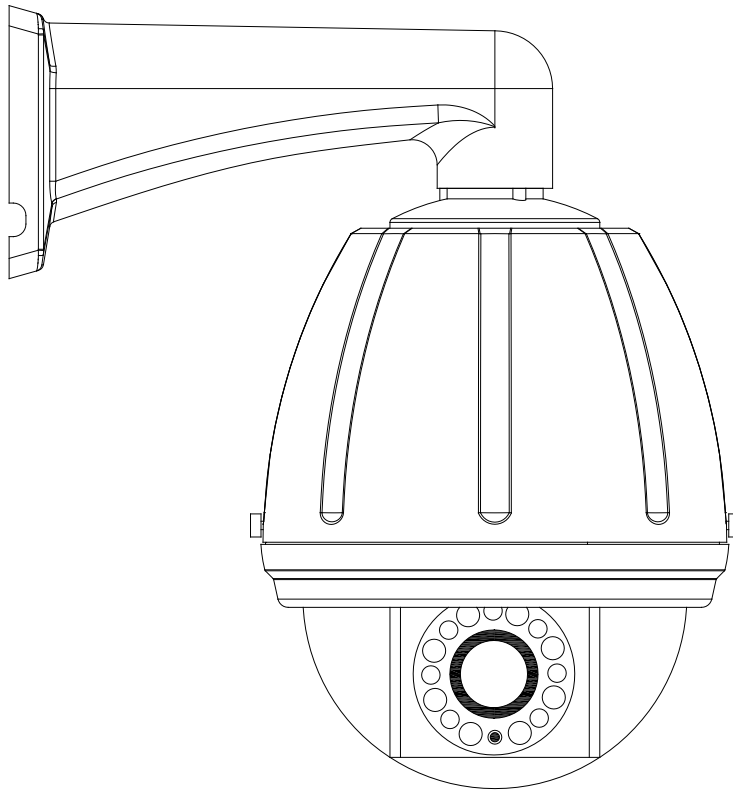

# **PEDOMEOIR48023SD**

## **Smart Constant Speed Dome Camera User Manual**



- Please read the manual carefully before installing and using the unit. ●

## **Part I: Introduction**

### **1-1. Instructions**

We greatly appreciate your choosing our product!

As stated in the warranty instruction, when a breakdown occurs to the properly used product, the product under warranty will be granted free maintenance or spare parts replacement. Do not disassemble or maintain the unit without the company's authorization.

Within one year from the purchase date, if any damage or breakdown occurs to the product (excluding housing, bracket and external wires) when it is properly used, we will provide free maintenance or spare parts replacement after our technician confirms the case.

No free maintenance under the following circumstances:

1. Damage or breakdown arising from the dismantling or repairing of the unit without the company's authorization;
2. Damage or breakdown arising from the client-arranged transportation, loading or unloading of the unit;
3. Damage or breakdown arising from using and maintenance of the unit without observing the instructions in the User's Manual, including damage or breakdown arising from crashing, crushing, and unit affected with liquids, damp, corrosive or other man-made causes.
4. Damage or breakdown arising from inapplicable operating ambient or overloaded operation; surface abrasion or damage emerging when the unit is used;
5. Damage or breakdown arising from natural disasters and other accidents.

Attention: To realize all the functions of the unit, a compatibility test must be carried out before applying other manufacturer's spare parts in the system.

### **1-2. Characteristics**

1. The design of the outer housing of the Constant Speed Ball is reasonable,

elegant and practical. The outer housing can endure long-term operation without distortion.

2. Precise conductive slip-ring is adopted, with which pan 360° endless running is realized and all-direction monitoring effect is realized.
3. The function of Position Limiting is realized by photoelectrical sensors, which avoids the limitations of traditional mechanical Position Limiting.
4. The operation is based on advanced stepper motors and driving circuits, which ensures smooth running, long time consecutive working, long lifespan and high reliability.
5. The running speed of the unit can be adjusted according to actual conditions.
6. Left/right limiting positions can be setup on the key-press of ball panel, it also can be set up through long-distance control of our company's keyboard.
7. The installation of the unit is fast, convenient and more human, which greatly reduces the inconvenience in installation.
8. The unique wall bracket installing style enables the placing of our company's adaptor inside the bracket.
9. The built-in decoding board supports multi mainstream protocols, and many more protocols can be input according to the customer's needs. The Baud rate is also adjustable.
10. The unit adopts DC12V power supply and separates from it the components that produce heat in the process of transformation, which prolongs the durability of the unit. The unit possesses the functions of anti-jamming and anti-crashing. It also features memory function, which enables the unit to automatically resume the last-time operated condition once supply of power is on after the power-off state.
- \*11. The unit has one default position; the user can preset the default position for a key monitoring area according to the actual conditions. If not operated after 5 minutes, the constant speed ball will automatically monitor the preset position.

**Remarks: The function of item 11 can be realized only when the protocol adopted supports the keyboard produced by this company. Also, the user can include our protocols into the DVR or existing software.**

### **1-3. Main Technical Data:**

#### **1. Electric Index**

- Power supply: DC12V /4A~ DC15V /4A  
Dome motor: DC12V /0.5A  
Camera power supply: 12V/2A  
Temperature controlling devices ambient: fan,  $\geq 50^{\circ}$ ; heater,  $\leq 5^{\circ}$   
Addresses range: 1~63  
Communication system: RS485 bus-mastering  
Communication protocol: supporting multi protocols  
Baud rate: 1200bps(19200bps)、2400bps、4800bps、9600bps、 as per customers' needs  
Controlling device: video matrix, hard disk video recorder, DVR controlling

keyboard

Pre-set position quantity: 16 preset positions

Tour group quantity: 1 group (16 preset positions can be included)

## 2. Mechanical Index

Dome movement: pan 360° endless, tilt 0°-90°

Dome speed: pan/tilt, Pan 6°、9°、12°、15° adjustable

Movement limiting position: adjustable between any two points

## 3. Ambient Index

Ambient temperature: 0°C~49°C (without temperature controlling devices)

-35°C~49°C (with temperature controlling devices)

Relative Humidity: below 90%RH

## 1-4. Styles of Installation and Ancillary Components

Table 1: Styles of Installation and Ancillary Components of Constant Speed Ball

Table 1: Styles of Installation and Ancillary Components

The style of installation	Bracket	cables (with connector)	Ancillary components	
			Power supply	temperature - controlling device
Wall mount installation	Wall-mount bracket	Power supply connecting cable, video connecting cable, RS458 connecting cable	DC 12V /4A	Required below 0°C
Pendant mount installation	Bracket length: 20cm (standard) or 40cm			
Ceiling mount installation	No bracket; Steel wire rope to be prepared by the user			

## Part II: Installation Procedures

### 2-1. Outer shape and installation size

#### Outer shape and installation size

Picture 1 Outer shape and size of wall mount style

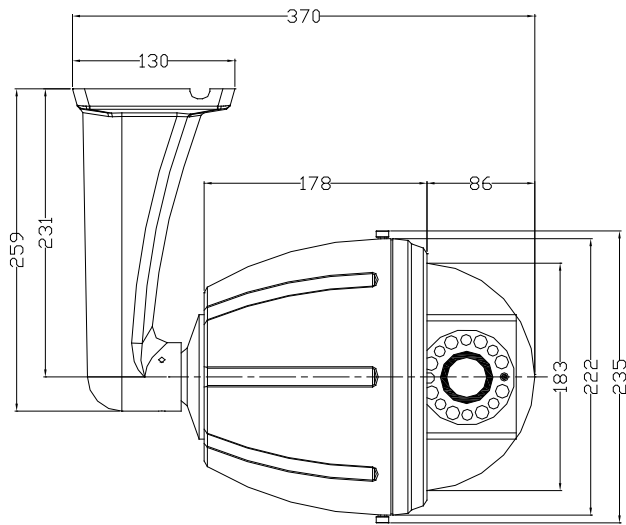

Picture 2 Outer shape and size of pendant mount style

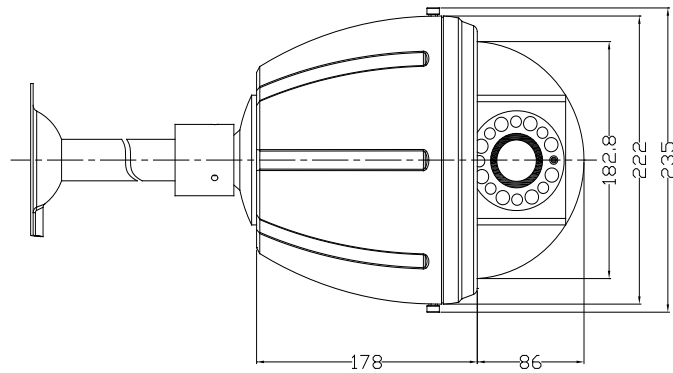

Picture 3 Outer shape and size of ceiling mount style

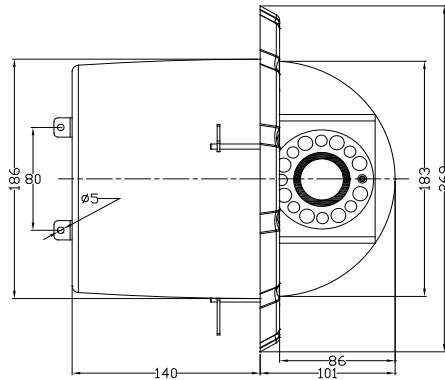

## 2-2. Installation of Video Camera

### Connecting Lens Controlling Cable

Camera Lens Controlling Cable should be provided by the camera supporter. Connect the Camera Lens Controlling Cable well according to the corresponding relationship between the camera and the outlet of decoding panel shown in the following table.

Controlling signal of the camera lens	Corresponding outlet on decoding panel
Camera power supply	+12VDC、GND
Lens Zoom	ZOOM
Lens Focus	FOCUS
Lens Iris	IRIS
Lens Controlling public ground	COM

### 3. Connecting Video Cable

Connect BNC video outlet with the video output outlet of the camera, then use the binding wire to tie the video cable inside the camera and the lens cable into the hole beside the lens connecting outlet on the decoding panel. After installing the camera, please setup communication protocol, baud rate, address, etc.

## 2-3. Installation of the Whole Housing and Bracket

Screw slot

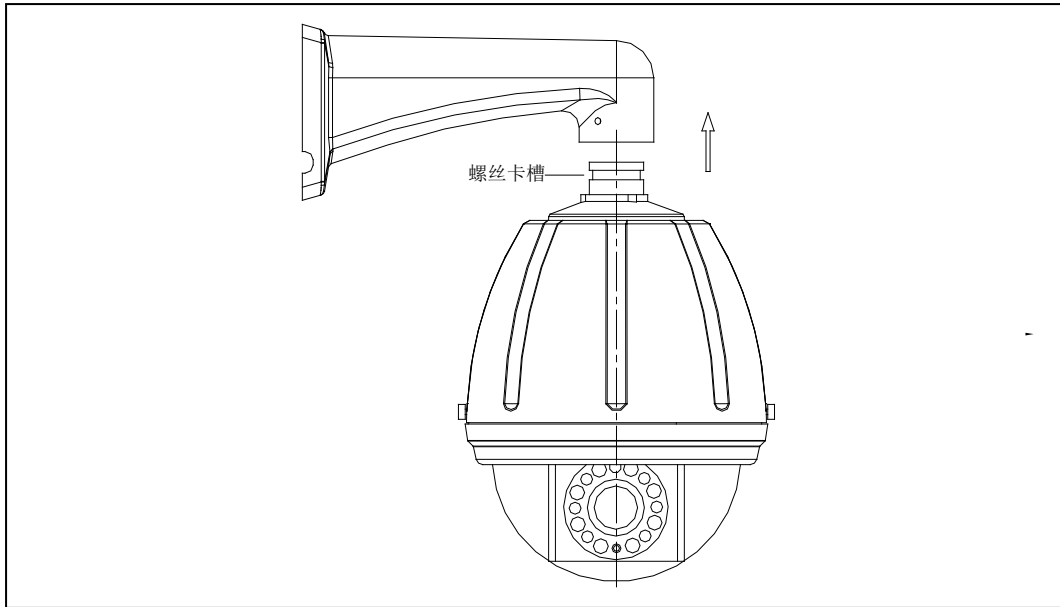

Picture 4



Push the connecting ports end of the power, video and RS458 controlling integrated cable through the round hole of the bracket, and then fix the ball housing top to the round hole of the bracket. Fix the three M6 screws with screw knife, enabling the screws to get into the screw slots. (See Picture 4))

## 2-4. Installation of Bracket of Constant Speed Ball

☆ Installation of bracket of outer-door Constant Speed Ball of wall mount type

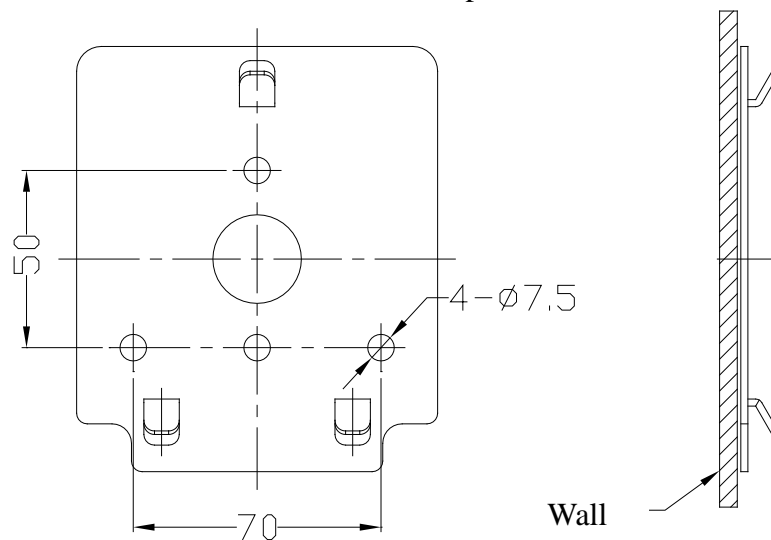

Picture 5 Size of bracket of outer-door Constant Speed Ball of wall mount type

Select the position for installation of Constant Speed Ball and confirm the place with good endurance ability, mark the corresponding positions of  $4 \phi 7.5$  installation holes of wall mount bracket on the wall with a pencil, then install the peg-board of the bracket in the wall with expanding bolts (not provided). (See picture 5)

☆ Installation of bracket of outer-door Constant Speed Ball of pendant

mount type

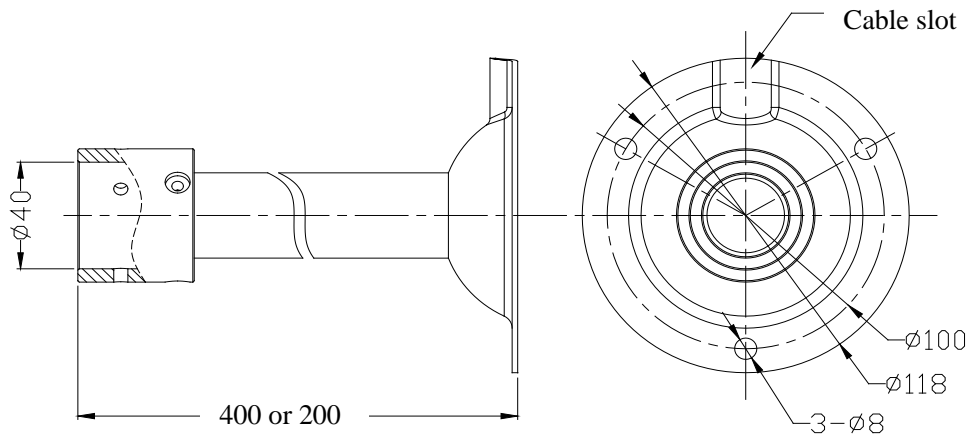

Picture 6: Size of bracket of outer-door Constant Speed Ball of pendant mount type

Select the position for installation of Constant Speed Ball and confirm the place with good endurance ability, mark the corresponding positions of 3 installation holes of the fixing tray on the ceiling with a pencil, then install the fixing tray in the ceiling with expanding bolts (not provided). Please don't forget to push the connecting ports end of the power, video and controlling integrated cable through the in-going slot of the bracket (See picture 6).

### 2-5. Fixing of the Set

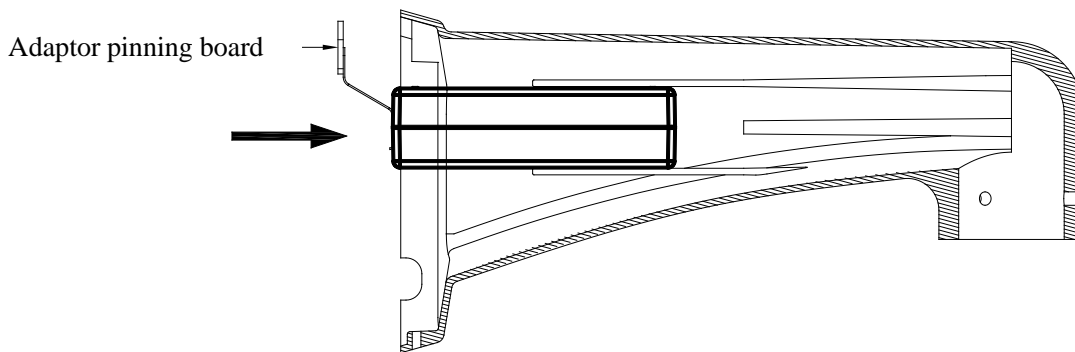

Picture 7

Step 1: Put the power adaptor into the well-connected bracket of pendant mount type and pin the power adaptor with the adaptor pinning board lest the adaptor slides out. (See picture 7)



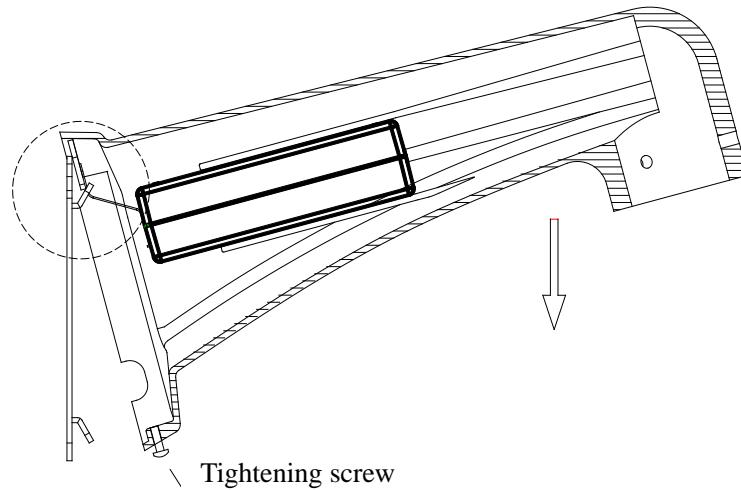

Picture 8

Step 2: Pull the power cable, video cable and controlling cable out via the cable out-going slot, then direct the dotted-line part of the bracket shown in the figure to the two corresponding pegs on the installed peg-board, then push the bracket downward until it locks in place. Make sure the bracket fits well with the peg-board, then tighten the screws on the bracket with the peg in underside part of the peg-board. (See Picture 8)

## 2-6. Installation of Half Ball

Locations with suspended top suit the constant speed ball with in-ceiling installation style, which appears to be a hemisphere, having an elegant look and good concealment. The hemisphere style installation applies to solid locations of the ceiling. First, select the desired location, mark the outline of the upper housing on the ceiling with a pencil and make a corresponding-sized bore, then insert the upper housing into the ceiling, and press the spring pinning boards against the edge of the ceiling opening. After that, tighten the screw adjusting the spring pinning boards, and lock the upper housing in the ceiling tightly. For the sake of better safety, please use a metal wire rope to connect the top of the upper housing to a reinforced structure of the ceiling. (The wire rope is required to bear at least 5 times the weight of the constant speed ball.) (See Picture 9)

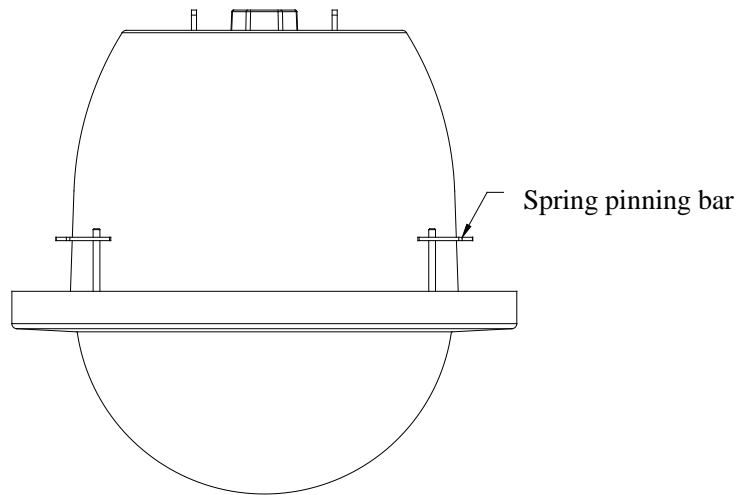

Picture 9

## 2-7. Connection of Power Supply Cable and Signal Cable

The connection of cables begins with the completion of installation.

1. Please see in table 1 the application of cables

Table 1

Cable	Application	Connecting objects	Remarks
4-strand cable	DC12V power supply	Decoding PCB penal —Power Supply Adaptor	Power outlet
	485 controlling signal	Decoding PCB penal — controlling device	Green(+) white(-)
Video cable	Camera signal	Camera — monitoring device	BNC connector
Power cable for temperature controlling device	DC12V power supply	Temperature controlling device — power supply adaptor	Parallel connection with the power supply of Decoding PCB penal
Camera lens controlling cable	Camera lens control/ power	Decoding PCB penal — camera	Provided with the integrated camera (including power cables)

2. Connection of temperature controlling power cable

If the bought products are with temperature controlling function, users can select those suiting application environments with reference to the selecting conditions of Picture 2 (connection of temperature controlling power cable) and connection of power supply cable and RS485 cable.

3. Connect the outlet of 12V power supply with power connector of the set core. Connect the 485 controlling cables to the provided 485 interfaces of the ball set, green to 485+, white to 485-.

4. Connection of Video Cable

Please weld a BNC connector to the already installed video cable, and then

connect to the video outlet provided by our company.

Now, all the power cables and signal cables have been connected. Please check carefully to guarantee correctness and firmness of all connections.

5. Finally, please connect the 220V interface of our company's provided special adaptor to AC220V power supply.

## **Part III: Setup the Functions of the Ball**

### **3-1. Setup of Communication Protocol, Baud Rate and Address of**

#### **Constant Speed Ball**

The constant speed ball has built-in Decoding PCB penal, the control of the dome and camera lens is realized by setting up address, protocol and baud rate through the decoding PCB penal.

##### **1. Address Setup**

As shown in the picture 10 and picture 11, DIP-1 to DIP-6 of the 8-button coding switches is used to setup address of the constant speed ball from 1 to 63. Control can be realized only when address code of the constant speed ball is identical to that of the hard disk video camera or matrix or controlling keyboard. The coding switches from DIP-1 to DIP-6 are equivalent to a 6-bit binary figure. The state "ON" of each bit means "1" while "OFF" means "0". Table 2 shows states of coding switches.

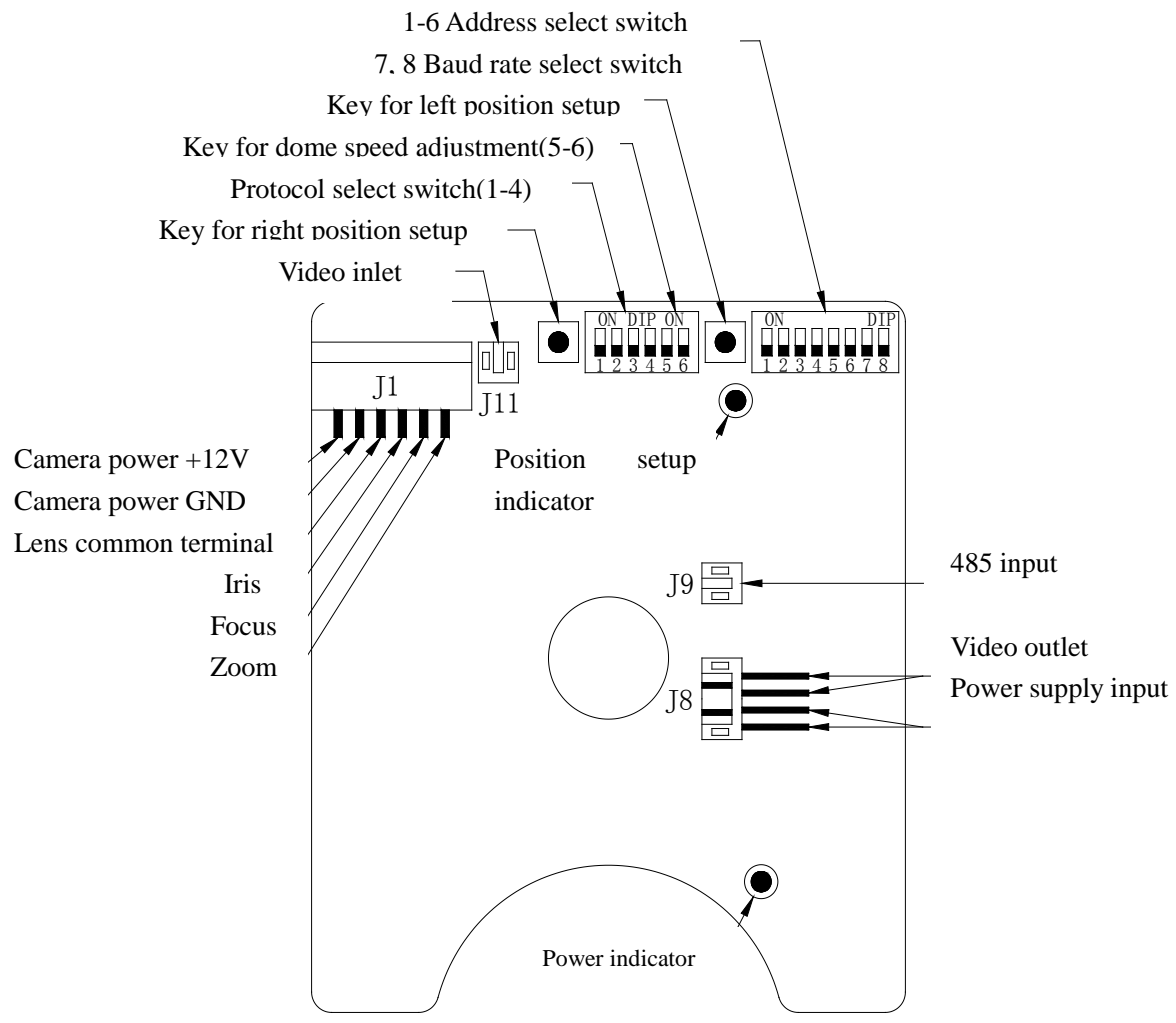

Picture 10

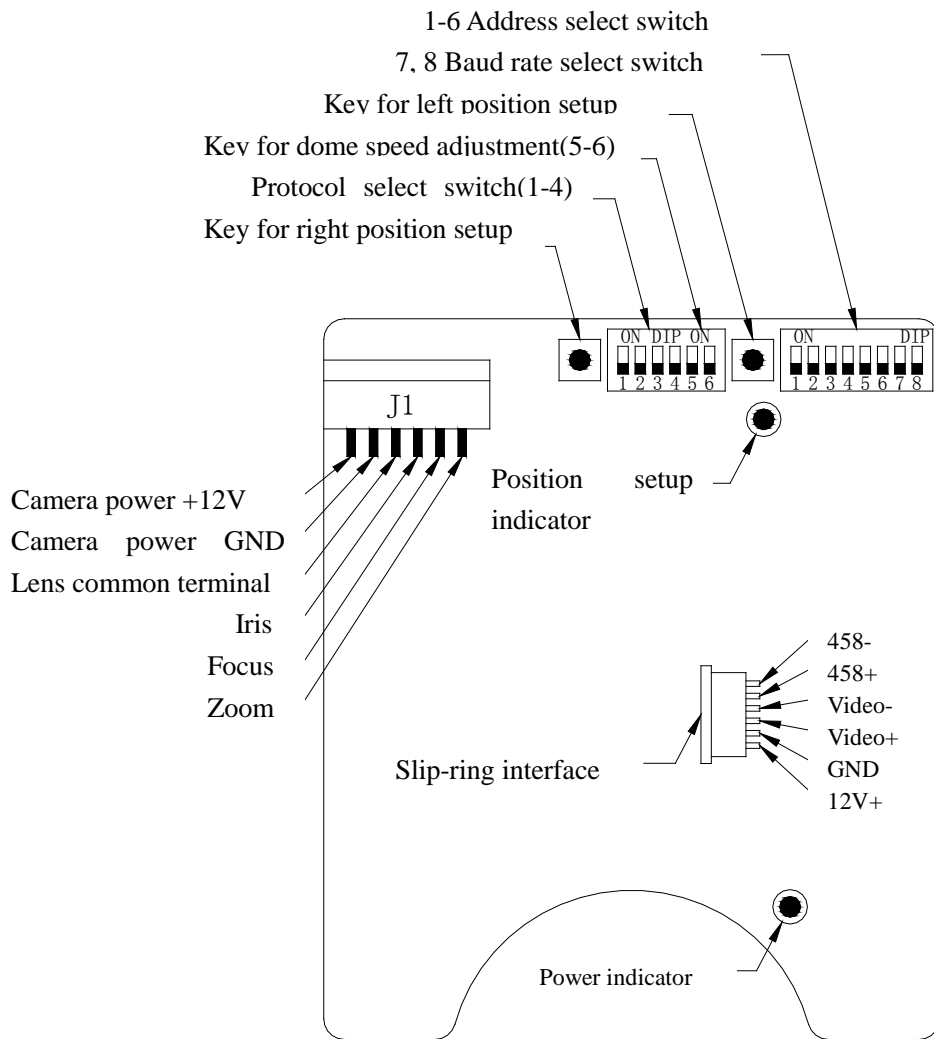

Picture11: Position of select switches of decoding PCB penel

**Table 2: Correspondence of Address and Coding Switches**

No	654321	No	654321	No	654321	No	654321
1	000001	17	010001	33	100001	49	110001
2	000010	18	010010	34	100010	50	110010
3	000011	19	010011	35	100011	51	110011
4	000100	20	010100	36	100100	51	110100
5	000101	21	010101	37	100101	53	110101
6	000110	22	010110	38	100110	54	110110
7	000111	23	010111	39	100111	55	110111
8	001000	24	011000	40	101000	56	111000
9	001001	25	011001	41	101001	57	111001
10	001010	26	011010	42	101010	58	111010
11	001011	27	011011	43	101011	59	111011
12	001100	28	011100	44	101100	60	111100

13	001101	29	011101	45	101101	61	111101
14	001110	30	011110	46	101110	62	111110
15	001111	31	011111	47	101111	63	111111
16	010000	32	100000	48	110000		

Protocol KRE-301 for KODICOM card hard disk video recorder, protocol PELCO-D and RM110 for Shanghai Chenova hard disk video recorder all adopt the hexadecimal system, which is different from other protocols adopting decimal system, so the address should be converted into decimal system. For details, please see coding switches in Table 3.

**Table 3: Correspondence of Hexadecimal Address and Coding Switches**

No	654321	No	654321	No	654321	No	654321
1	000001	5	000101	9	001001	13	010011
2	000010	6	000110	10	010000	14	010100
3	000011	7	000111	11	010001	15	010101
4	000100	8	001000	12	010010	16	010110

Please setup coding switches according to Table 2 or Table 3 as per the address you defined by yourself.

## 2. Communication Baud Rate Setup

As shown in picture 11, DIP-7 and DIP-8 of the 8-button coding switches are used to setup Baud rate of communication and 4 different Baud rate can be selected (1200BPS/2400BPS/4800BPS/ 9600BPS). The state “ON” of each bit means“1”, while”OFF”means”0”. Table 4 shows states of correspondence of Baud rate and coding Switches.

**Table 4: Correspondence of Baud Rate and Coding Switches**

Coding switches	1200 bps	2400 bps	4800 bps	9600 bps
No. 7	OFF	ON	OFF	ON
No. 8	OFF	OFF	ON	ON

Please setup the coding switches according to Table 4 based on the communication baud rate applied for constant speed ball device.

## 3. Protocol Setup

As indicated in the picture 11, DIP-1 to DIP-4 of the 6-button coding switches are used to setup protocol of the constant speed ball. The built-in Decoding PCB penal provides protocols as listed in Table 5. Other protocols can also be written-in as the user requires.

**Table 5 Correspondence of Coding Switches and Protocols.**

No.	DIP- 4,3,2,1	Types of Protocols
1	0 0 0 0	PELCO_D
2	0 0 0 1	PELCO_P
3	0 0 1 0	VICON
4	0 0 1 1	PELCON
5	0 1 0 0	KALATEL-312
6	0 1 0 1	CCR-20G
7	0 1 1 0	ADR-8060
8	0 1 1 1	HY
9	1 0 0 0	M800-CIA
10	1 0 0 1	PANASONIC
11	1 0 1 0	LILIN
12	1 0 1 1	KRE-301
13	1 1 0 0	WISDOM
14	1 1 0 1	RM110
15	1 1 1 0	NEW
16	1 1 1 1	PELCO_D1

The built-in Decoding PCB penal provides the above sixteen protocols. More protocols can also be provided as the user requires, such as:

Communication protocols with matrix: SAMSUNG, KONY Matrix, TDTC Matrix, PELCO Matrix, VICANYX Matrix and LP Matrix.

Communication protocols with hard disk video recorder: CNEUOL embedded, Enterasys embedding, DM embedding, Hikvision embedding, KCL, YAAN, SAMSUNG, KIDICOM-SX. For information of hard disk video recorder protocols and Baud rate, please refer to Table 6.

Communication protocols with keyboard: Video keyboard, PWT keyboard, Samsung keyboard and YAAN keyboard.

**Table 6: Reference for Hard Disk Video Recorder Protocols and Baud Rate**

KOMSA series hard disk	PELCO-D 2400, RM110 9600, HY 9600
MPG4 card of Viewse software	HY 9600, PELCO-D 2400, RM110 9600
MPG4 card of Shanghai Chenova software	PELCO-D 2400, RM110 9600
KODICOM hard disk	PELCO-D 2400, LILIN SD 9600, KRE-301 9600
PICO video collection card	PELCO-D, KTD-312, VICON, etc, Baud rate adjustable
PICASO hard disk	PELCON 2400, PELCO-D 2400, CCR-20G 4800
MPG4 card of DVTECH Software	ADR-820 4800

MPG4 card of zhongjiaman Software	HY 9600, PELCO-P 2400
Image sensitive card (Chengdu Kony)	M800-CIA 2400
MPG4 card of Milky Way software	PELCO-D 2400, WISDOM 4800

Please choose appropriate communication protocols according to the protocols adopted by constant speed ball controlling equipment (such as matrix, HD video recorder, keyboard). Before installation, a compatibility test of controlling and controlled equipment is recommended.

To control the three alternative camera lens of KODICOM HD video recorder, please adopt KRE-301 protocol. Operation is shown below:

Switch on the "POWER" button on the top of the controlling interface and press the focus button, and then the state is Iris control. Switch off the "POWER" button, and press the focus button, then it will resume focusing control.

#### 4. Functions Setup of the Constant Speed Ball

Code Name of the function	Definition for the keyboard operation	Code Name of the function	Definition for the keyboard operation
<b>160</b>	Begin with left/right limiting position setup	<b>140</b>	Begin with the tour group setup
<b>161</b>	Finish left/right limiting position setup	<b>141</b>	Finish the tour group setup
<b>130</b>	Setup left limiting position	<b>142</b>	Start Tour Group
<b>131</b>	Setup right limiting position	<b>162</b>	Activate Home Position function
<b>132</b>	Start left/right scan	<b>163</b>	Disable Home Position function
<b>135</b>	Start 360°scan of the dome	<b>164</b>	Setup Home Position
<b>138</b>	Stop auto scan of the dome		

**If preset position numbers larger than 128 could not be previewed on the controlling device, please choose PELCO-D1 protocol, functions operation table as below:**

Code Name of the function	Definition for the keyboard operation	Code Name of the function	Definition for the keyboard operation
<b>120</b>	begin with left/right limiting position setup	<b>110</b>	Begin with the tour setup
<b>121</b>	Finish left/right limiting position setup	<b>111</b>	Finish the tour setup



<b>100</b>	Setup left limiting position	<b>112</b>	Start Tour
<b>101</b>	Setup right limiting position	<b>122</b>	Activate Home Position function
<b>102</b>	Start left/right scan	<b>123</b>	Disable Home Position function
<b>105</b>	Start 360°scan of the dome	<b>124</b>	Setup Home Position
<b>108</b>	Stop auto scan of the dome		

## 5. Setup the Movement Speed of the Dome

The movement speed of the dome can be setup through the coding switch. DIP 5 and DIP6 of the 6-button coding switch (see figure above) are used to setup the movement speed of the dome. Please refer details as Table 5:

No.	DIP: 5, 6	Circling speed
1	00	6°
2	10	9°
3	01	12°
4	11	15°

Table 5

### 3-2. Running state examination while Supplying Power to the Unit

Once the power supply begins, check whether the power indicator on the PCB panel is on. Now the constant speed ball begins with self-check. After the self-check, the position of the dome is horizontally on the left limiting position, tilt 30°. Two states may follow the self-check:

- a. The constant speed ball makes no action
- b. The constant speed ball is in the state of pan auto- touring

If the constant speed ball is in the state of pan auto-touring, the tour should be stopped through the controlling device to avoid possible friction or collision between camera cable and inner housing caused by inappropriate installation of the camera.

After installing the vitreous cover, control the constant speed ball to make slow pan/tilt movement, and observe its agility and stability, and check whether there is friction or collision between camera, cable and inner housing.

If the ball movement is unstable and with noise, please check whether the connection between the constant speed ball and the bracket is vertical, or whether the ball movement is in good connection with the peg-board. If not, switch off the power supply, then check and re-install the unit following the above-mentioned installation instructions.

If there is friction or collision between the camera, cable and the inner housing, switch off the power and open the vitreous cover to adjust the position of the camera on the suspender, or tidy up the cables inside the inner housing. Then reinstall the vitreous cover.

Switch on the power again, control the constant speed ball to make slow pan/tilt movement, observe its agility and stability, and check whether there is friction or collision between camera, cable and inner housing.

If the process goes smoothly, you can adjust the scope of pan scan, i.e. scope of maximum left/right positions.

**Functions Setup: If PELCO-D1 protocol is chosen for the control, please choose the Function Codes inside the bracket to operate.**

### 3-3. Setup and Preview Preset Positions

The function of preset positions works in this way: the constant speed ball saves the current pan/tilt parameters in number order (1-16), quickly previews those parameters when needed, and adjust the dome to the corresponding positions. Users can use such devices as controlling keyboard to save and preview preset positions fast and conveniently. The constant speed ball can support 16 preset positions.

#### 1. Setup preset positions

After controlling pan/tilt of the constant speed ball to desired position through the keyboard, enter the number representing the preset position and LED displays the entered preset position number. Press the “PRESET” key, then LED resumes to previous displaying state again, now you have setup the preset position successfully. Example: Setup preset position No.1

- a. Use the joystick to move the constant speed ball to the desired position.
- b. Enter “1”
- c. Press the “PRESET” key

#### 2. Preview Preset Positions

The function enables the constant speed ball to quickly return to the preset position.

Enter the number key for preset position number which you need to preview; LED displays the preset position number.

Press the “PREVIEW” key, then the constant speed ball to the preset position. Example: Previewing Preset position No.1

- a. Enter “1”
- b. Press the “PREVIEW” key

### 3-4. Setup of Tours

Auto-tour is a latest new function of constant speed ball, tour course can be set casually through operation, and only an external command is enough to start the constant speed ball to tour according to regulated course. Tour group can keep 16

preset positions in memory at most.

Setup of tour group

- a. In the keyboard initial state, enter number “140”(110) and press the “PREVIEW” key to enter the tour setup.
- b. After entering the setup, add preset position number to the tour. Enter the first desired preset position number and press the “PREVIEW” key, and the first preset position is successfully added. Then it goes to the second one. Enter the second desired preset position number and press the “PREVIEW” key, and the second preset position is successfully added. More preset position can be added in the same way.
- c. After all the required preset positions having been added in the tour, enter the number “141”(111) on the keyboard and press the “PREVIEW” key to exit the tour setup.

### **1. Start Running a Tour**

In the keyboard initial state, enter number “142”(112) and press the “PREVIEW” key to start running the preset tour.

**Example: Setup the tour order to be 2→5→3→4→6 (please setup preset positions before tour setup)**

1. **Preview preset position 140(110) to enter tour setup (Enter number “140”(110) and press the “PREVIEW” key)**
2. **Preview preset position 1 to setup the first tour position (Enter number “1”and press the “PREVIEW” key)**
3. **Preview preset position 2 to setup the second tour position (Enter number “2”and press the “PREVIEW” key)**
4. **Preview preset position 5 to setup the third tour position (Enter number “5”and press the “PREVIEW” key)**
5. **Preview preset position 3 to setup the fourth tour position (Enter number “3”and press the “PREVIEW” key)**
6. **Preview preset position 4 to setup the fifth tour position (Enter number “4”and press the “PREVIEW” key)**
7. **Preview preset position 6 to setup the sixth tour position (Enter number “6”and press the “PREVIEW” key)**
8. **Preview preset position 141(111) to exit tour setup (Enter number “141”(111) and press the “PREVIEW” key)**
9. **Preview preset position 142(112) to start running the tour, and the constant speed ball runs the tour and begins to scan in the order of 1→2→5→3→4→6.**

**If other devices are used to control the constant speed ball, due to the protocol limitation, some special functions of the constant speed ball may be not operational. (Enter number “142” (112) and press the “PREVIEW” key)**

### **3-5. Setup of Left/right Limiting Positions**

The default rotating angle of the set is 360°. The user can reset running angle according to the spot requirements. Left/right limiting positions of the dome can be

setup in three ways:

**☆Setting the dome's left/right limiting positions through the company's special keyboard**

A. Once the dome is installed and power is on, the constant speed ball starts a self-check. After the self-check, the position of the dome is the left position, Setup the maximum left/right positions by the company's keyboard connected to the constant speed ball through 485 bus cable. First, setup the Baud rate, protocol and address of the keyboard identical with those of the constant speed ball, and make sure the keyboard can control the movement of the constant speed ball.

B. Enter the number "160"(120) on the keyboard, and press "PREVIEW" key to enter the setup of maximum left/right positions, then turn the joystick on the keyboard to the right direction till the dome reaches the desired point of right limiting position, then enter 131(101), and press "PREVIEW" key again, now the dome's right limiting position has been setup successfully. Next, turn the joystick on the keyboard to the left direction till the dome reaches the desired point of left limiting position, enter 130(100) and press "PREVIEW" key again, now the dome's left limiting position have been setup successfully. After the setup, enter 161(121) and press "PREVIEW" key to exit the setup. Now the setup of left/right limiting positions is completed.

**☆ Setting up the dome's left/right limiting positions through the coordinated operation of DVR and the buttons on the dome camera's master board (The operation requires the co-operation of two people)**

A. Once the dome is installed well and power is on, the constant speed ball starts a self-check. After the self-check, the position of the dome is the default left position of the constant speed ball. Open the vitreous cover, find on the dome camera panel the two keys-"S1", "S2", then, press the two keys simultaneously with your forefinger and middle finger for about 2 seconds till the green indicator—D11 is continuously on . The continuous-on state of the green indicator suggests entering the setup of the dome's left/right position.

B. Inform the personnel in the controlling room with an interphone, and the personnel should control through the DVR to move the dome right till it reaches the desired point of right position setup, and then the personnel should inform the person at the terminal that the constant speed ball is in the desired place. Then the person at the terminal should press key "S2" for about 2 seconds till the same green indicator glistens once. The glistening means the setup of the dome's right position is successful.

C. Once again, inform the personnel in the controlling room with an interphone, and the personnel should control through the DVR to move the dome left till it reaches the desired point of left limiting position setup, and then the personnel should inform the person at the terminal that the constant speed ball is in the desired place. Then the person at the terminal should press key "S1" for about 2 seconds till the same green indicator glistens once. The glistening means the setup of the dome's left position is successful.

D. On completing the setup of left/right limiting positions, press the two keys “S1” and “S2” simultaneously with your forefinger and middle finger for about 2 seconds till the green indicator—D11 is off. The off state of the green indicator suggests exit of the dome’s left/right limiting position setup. The exit of the dome’s left/right limiting positions setup can also be realized by switching off the power and, then, on again.

**☆Setting up the dome’s left/right limiting positions through keys on the ball set panel**

A. Once the dome is installed and power is on, the ball starts a self-check. After the self-check, the position of the ball is the default left position of the ball. Open the vitreous cover, find on the ball panel the two keys-”S1”, “S2”, then, press the two keys simultaneously with your forefinger and middle finger for about 2 seconds till the green indicator—D11 is continuously on. The continuous-on state of the green indicator suggests entering the setup of the dome’s left/right limiting position.

B. Next, press the key “S2” on the constant speed ball panel and then release it, then the dome begins to turn right. When the dome reaches the desired point of right position setup, press either “S2” or “S1” and then release it, and the dome will stop moving. If the dome goes out of the desired range, press the key “S1” on the constant speed ball panel and release it, then the dome begins to turn left. When the dome reaches the desired position, press either “S2” or “S1” and then release it, and the dome will stop moving. Finally, press the key “S2” for about 2 seconds till the green indicator glistens once. The glistening means the setup of the dome’s right limiting position is successful.

C. Then the setup of the left position follows. Press the key “S1” on the constant speed ball panel and then release it, then the dome begins to turn left. When the dome reaches the desired point of left position setup, press either “S2” or “S1” and then release it, and the dome will stop moving. If the dome goes out of the desired range, press the key “S2” on the constant speed ball panel and release it, then the dome begins to turn right. When the dome reaches the desired position, press either “S2” or “S1” and then release it, and the dome will stop moving. Finally, press the key “S1” for about 2 seconds till the green indicator glistens once. The glistening means the setup of the dome’s left limiting position is successful.

D. On completing the setup of left/right limiting positions, press the two keys “S1” and “S2” simultaneously with your forefinger and middle finger for about 2 seconds till the green indicator—D11 is off. The off state of the green indicator suggests exit of the dome’s left/right limiting position setup. The exit of the dome’s left/right limiting positions setup can also be realized by switching off the power and, then, on again.

**If the user wants to change the setup of left/right limiting positions after the setup has been done, please refer to the adjustment setup instructions.**

**Remarks:**

**Pressing two keys together for two seconds indicates entering or exiting the**

#### **setup of left/right limiting positions**

**Press the key “S1” once on the dome camera panel would move the dome left; the second press stops the movement.**

**Press the key “S2” once on the dome camera panel would move the dome right, the second press stops the movement.**

**Press the key “S1” for 2 seconds confirms the dome’s left limiting position.**

**Press the key “S2” for 2 seconds confirms the dome’s right limiting position.**

**The continuous-on state of the green indicator suggests entering of the left/right limiting position setup.**

**The off state of the green indicator suggests exit of the left/right limiting position setup.**

**The green indicator’s glistening once suggests confirming the dome’s left/right limiting position setup.**

### **3-6. The Setup, Entering and Exit of Default Position**

The unit has a default position. The user can setup default position for a key monitoring area according to actual conditions. If not operated after 5 minutes, the ball will automatically run to the default position.

#### **1. Setup of the Default Position**

Move the constant speed ball to a key monitoring area through the controlling keyboard, and enter number “164” (124) from the keyboard and press the “PREVIEW” key, and the setup is successful.

#### **2. Activate the Default Position function**

The user can activate the function of default position through the keyboard. Enter number “162”(122) and press the “PREVIEW” key, and the function is activated.

#### **3. Exit the Default Position function**

Enter number “163”(123) and press the “PREVIEW” key, and exit the function.

### **3-7. Start Left & Right Scan**

The ball has an Auto Scan function. After the Left and Right Limiting positions are setup well, if the scan between the two Limiting Positions is needed, you can operate on the keyboard directly, the operation is as below:

#### **1. Operation through previewing function code:**

- a. Input 132(102)
- b. Press PREVIEW key

#### **2. Direct operation on keyboard:**

Press AUTO key

Each of the above operation can start the scan between the two limiting positions.

### **3-8. Start 360° scan function of the dome**

The ball can carry out 360° scan function. So that all-direction scanning and monitoring effect is realized. User can operate directly on the keyboard. The operation is as below:

- a. Input 135(105)

- b. Press PREVIEW key  
Then the ball will carry out 360° endless scanning.

### 3-9. Stop the auto scan of the dome

While the unit is carrying out scanning operation, if you require the unit carry out other operations, you can operate on the keyboard to stop the auto scan. Operation is as below:

- a. Input 138(108)  
b. Press PREVIEW key

## Part IV: Appendix

### Simple troubles and corresponding solutions

Problems	Possible causes	Solutions
No action when connecting to power, no image, off state of the indicator	Wrong connection of power cable	Correct
	Power supply damaged	Replace
	Not required power type	Replace
	Bad power cable connection	Resolve
Self-check with power, image without control	Wrong setup of address code, baud rate of the ball set	Reset address code and baud rate of the ball set
	Wrong protocol	Correct
	opposite connection or disconnection of RS458 cable	Check connection of RS485 controlling cable
Unable to complete self-check, image with motor tweeting	Mechanical failure	Repair
	Tilt of camera	Adjust
	Power supply not enough	Replace it with suitable adaptor, you had better put the adaptor near to the ball set
Unstable image	Bad connection of video cable	Resolve
	Power supply not enough	Replace
No ceasing or deferred ceasing of ball set under control	Not enough power supply of ball set	Replace it with suitable adaptor, you had better put the adaptor near to the ball set
	Check if the matching resistance of the ball set farthest from control is added	Add the matching resistance of the ball set farthest from control

	485 signal is weakening, the driving of 485 convertor is not enough	Replace the convertor
--	---	-----------------------